

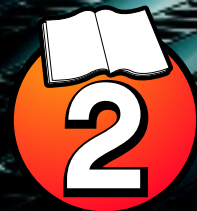

TECHNIC

42001

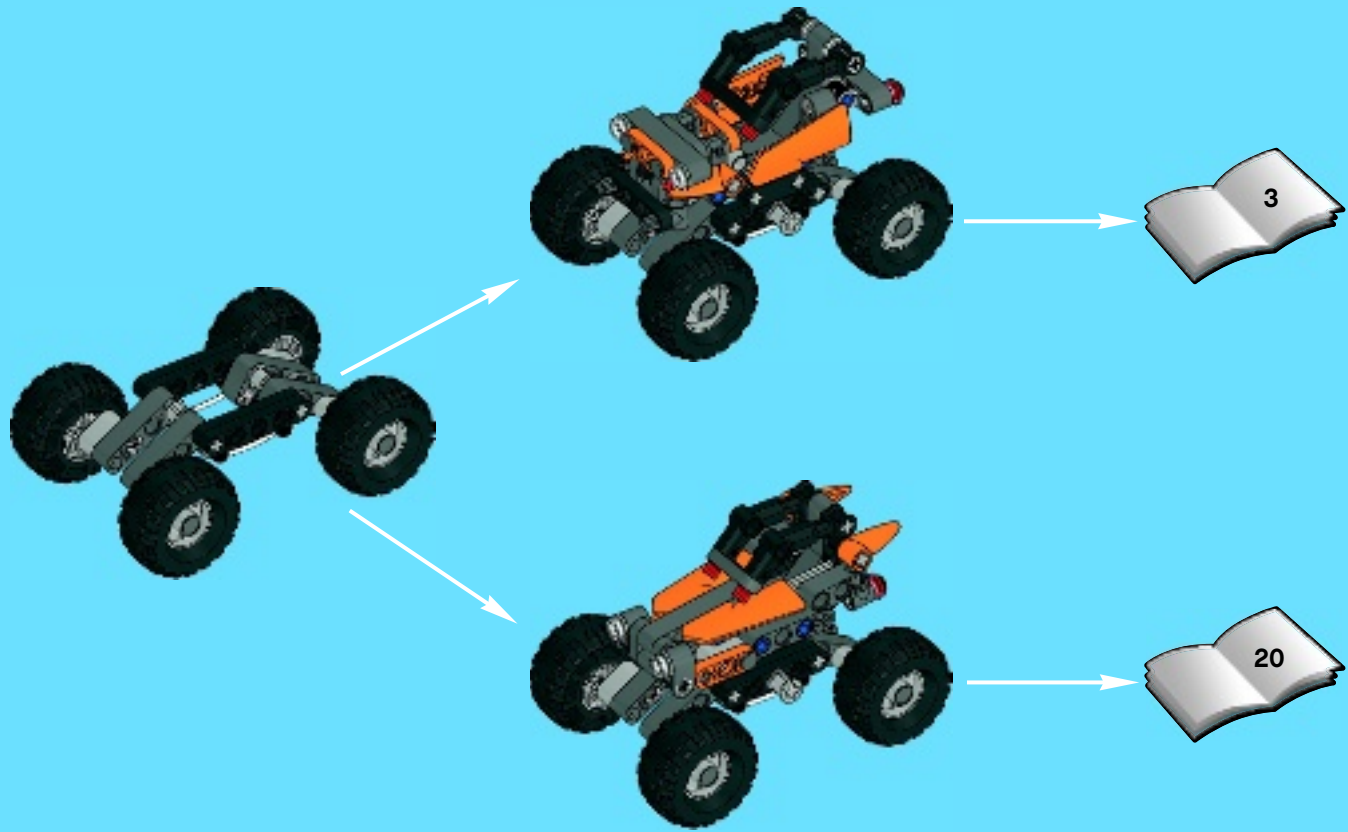



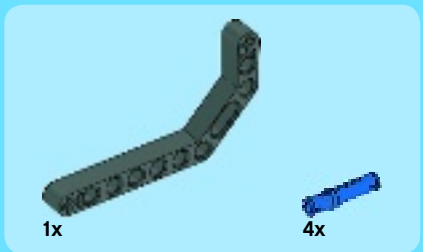

1

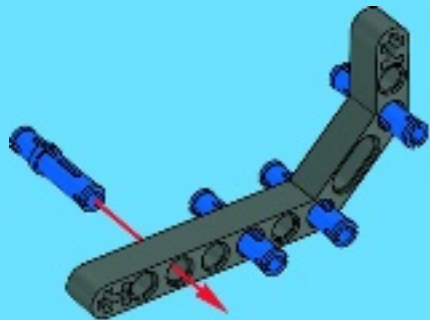

2

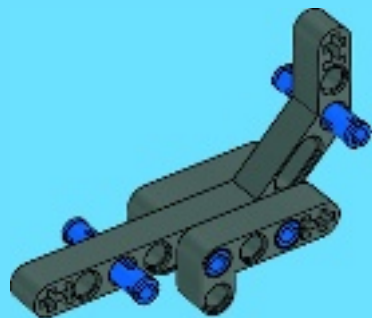

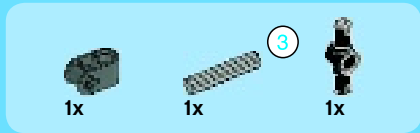

3

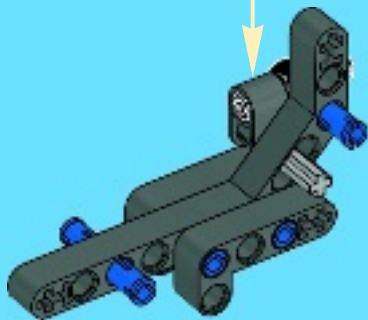
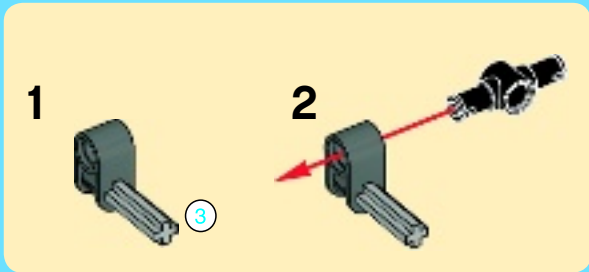

4

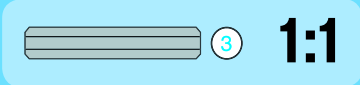



1x



1x

4

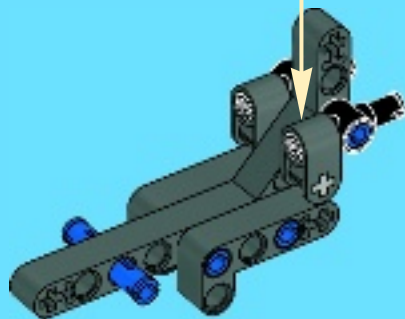
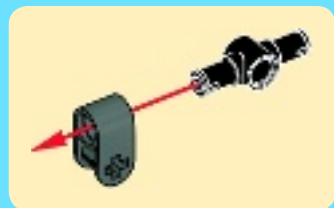

5

1:1



2x



2x



1x

5

5

1

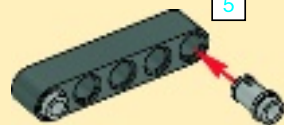

5

2

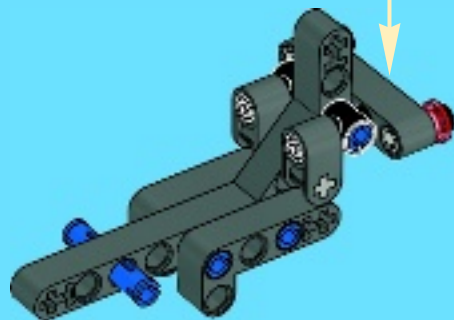
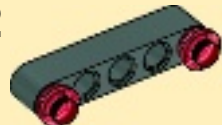

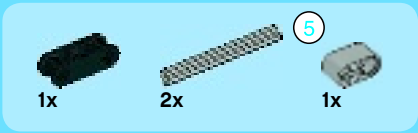

6

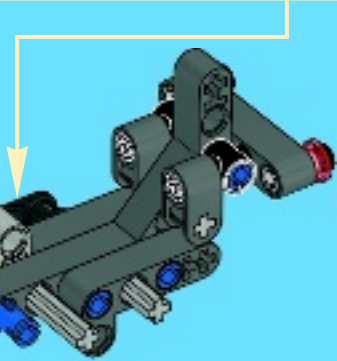
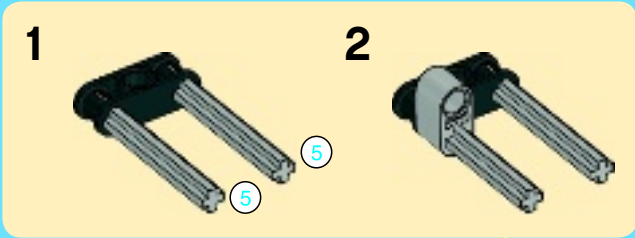

6

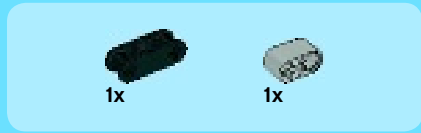

7

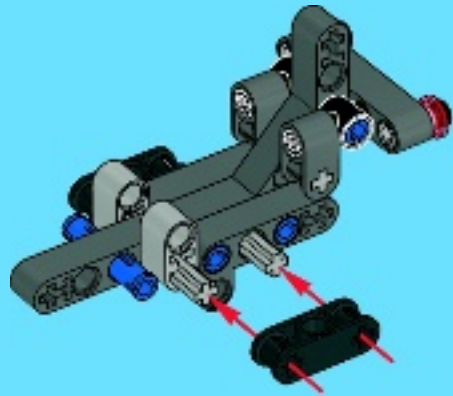



1x



1x

8

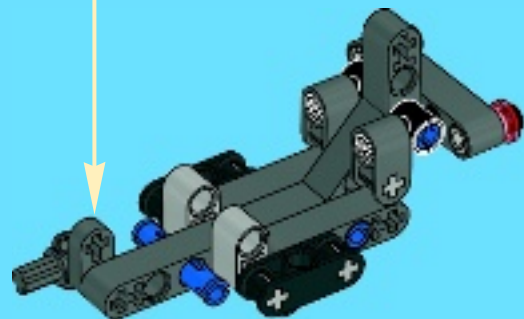
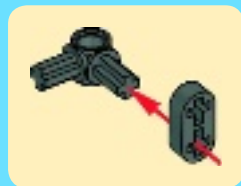

1x



1x

9

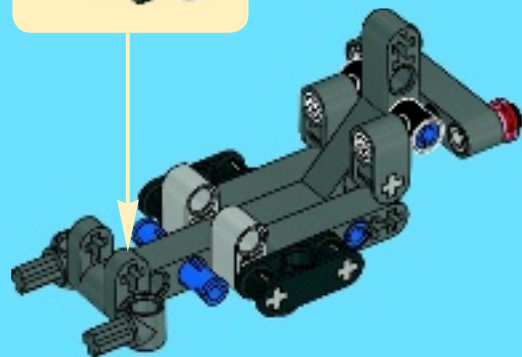
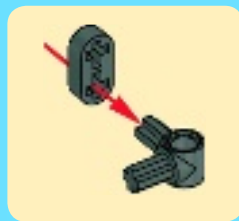



1x

10

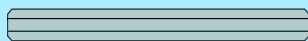
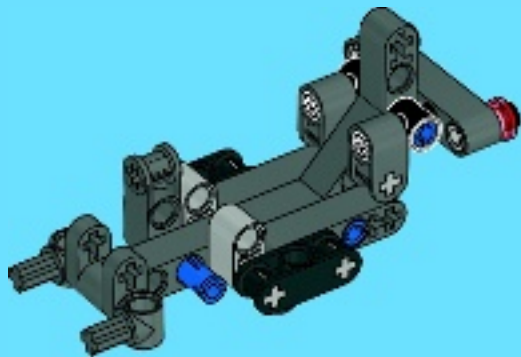

5

1:1

8



1x

5



1x

11

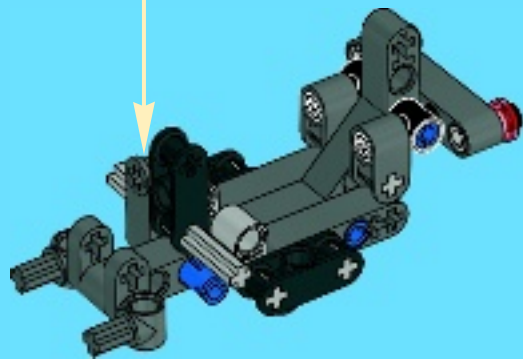



1x

12

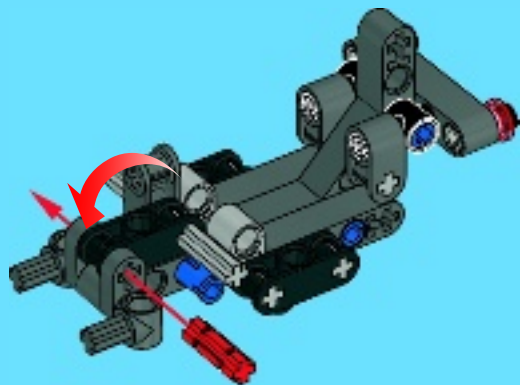

1x

13

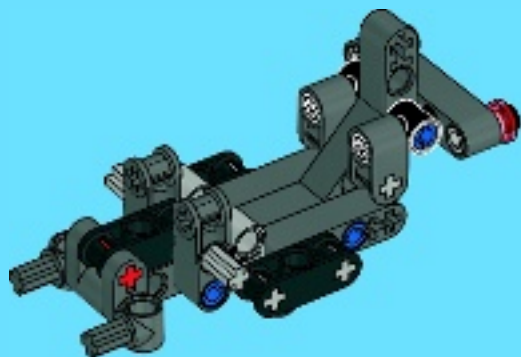



1x



2x

14

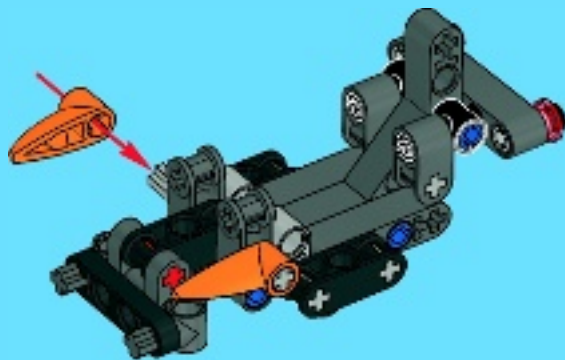

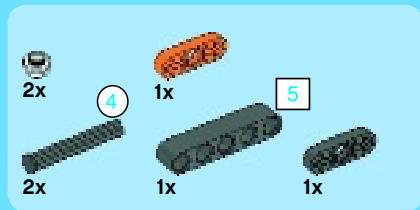

15

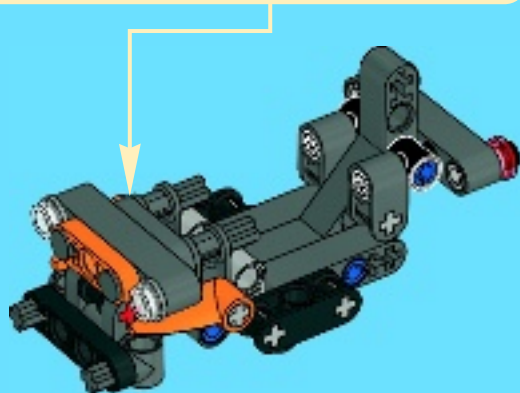
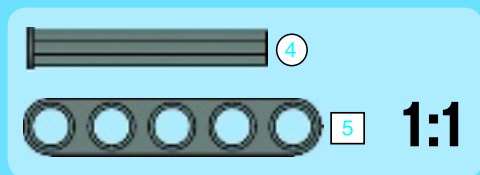
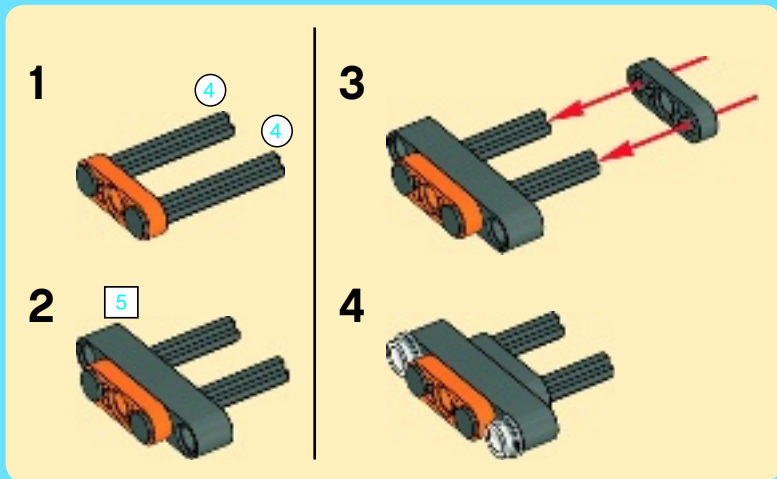



1x

16

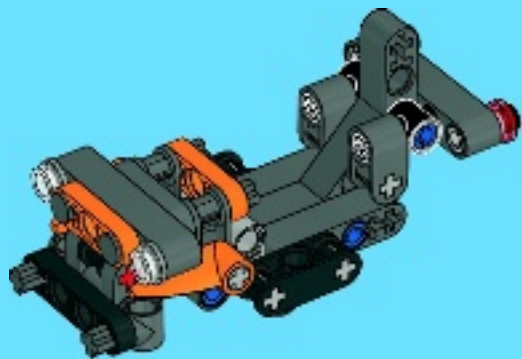

12



2x



22

1x



21

1x

17

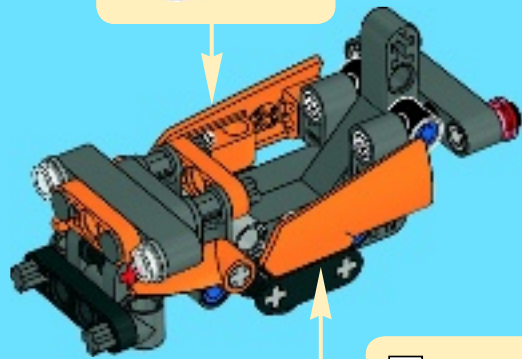

21

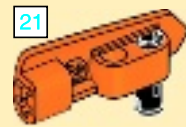



18

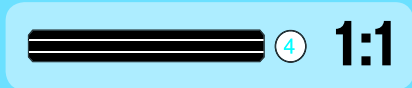
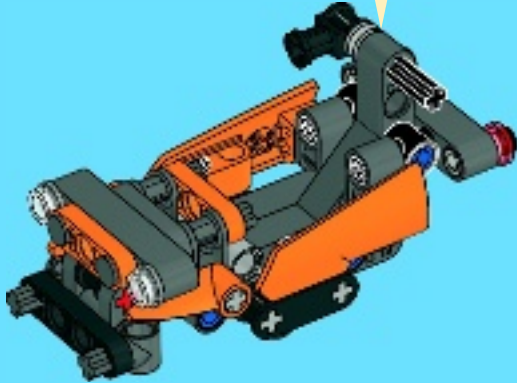
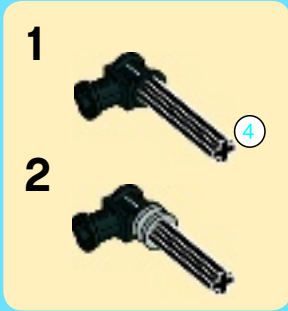



1x



1x

19

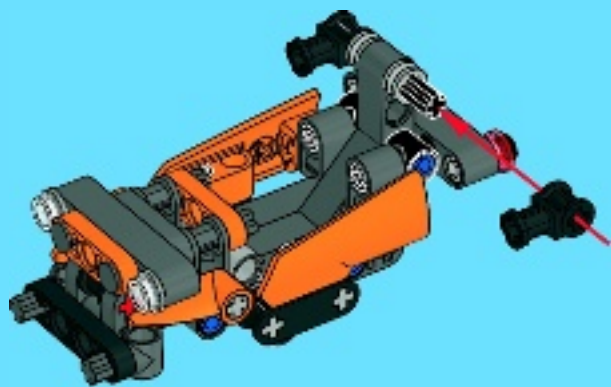

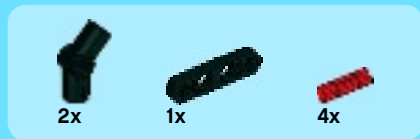

20

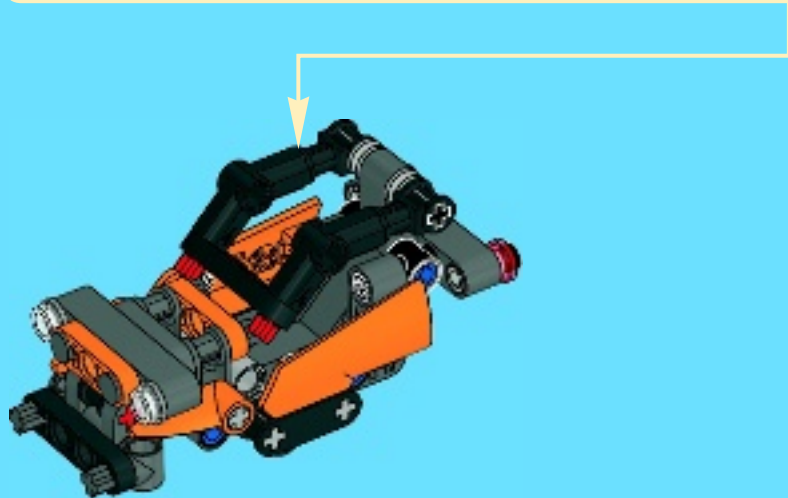

21

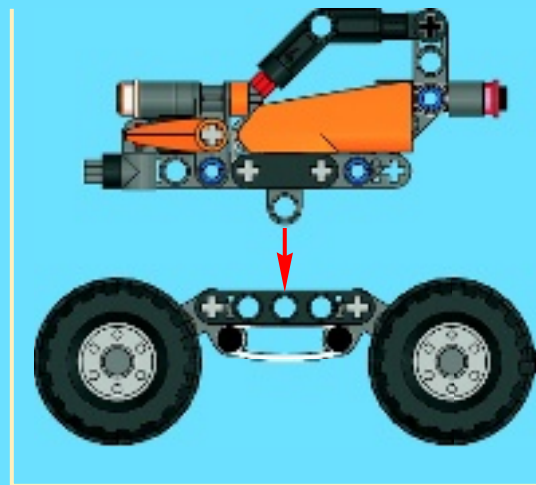

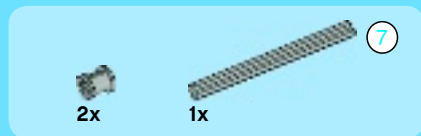

22

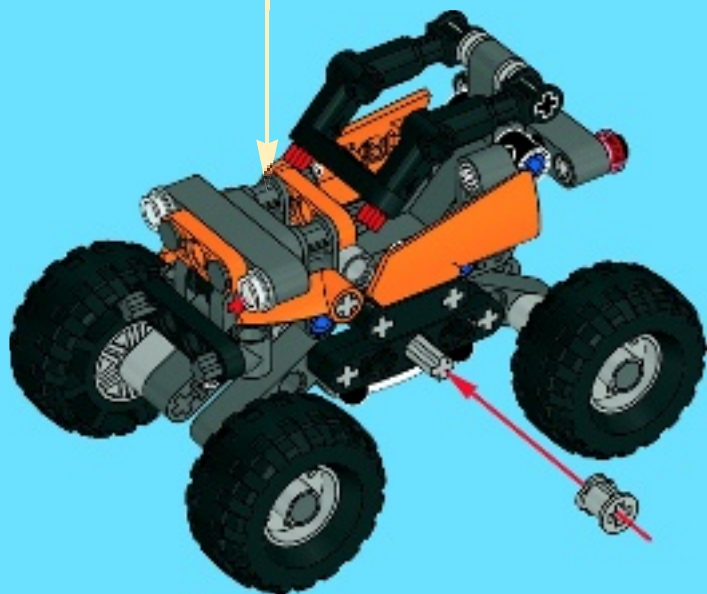

23



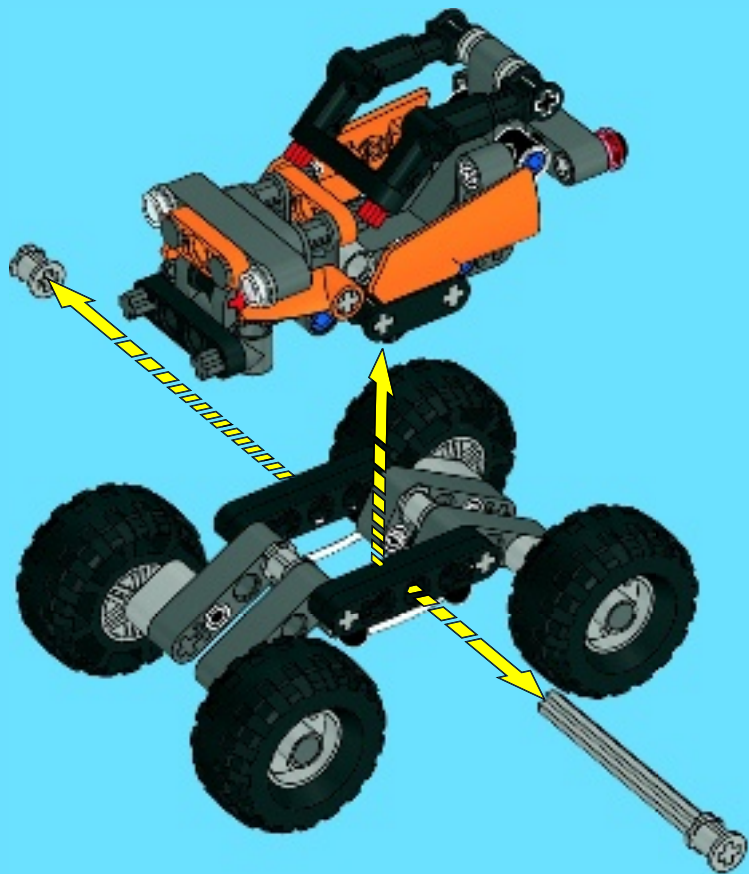

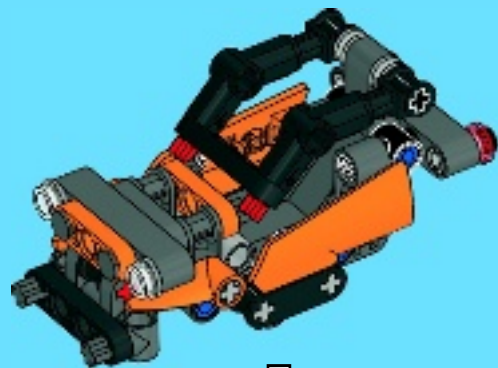
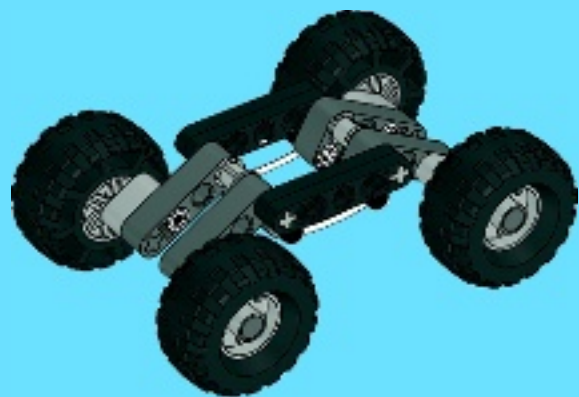

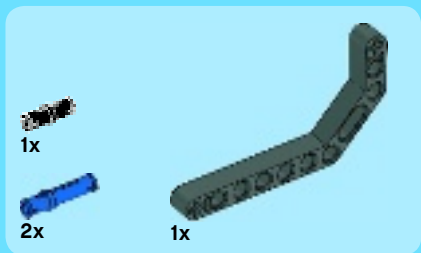

1

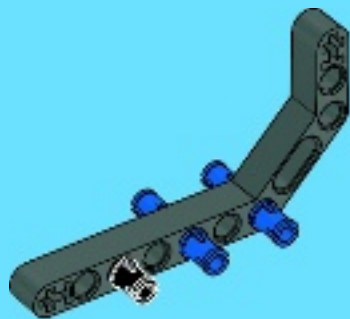

2

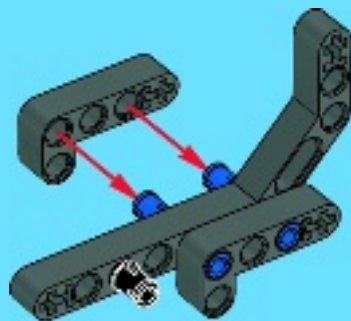

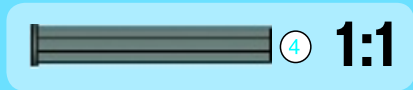
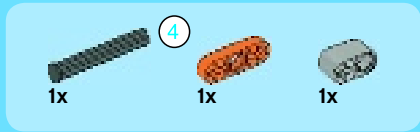

3

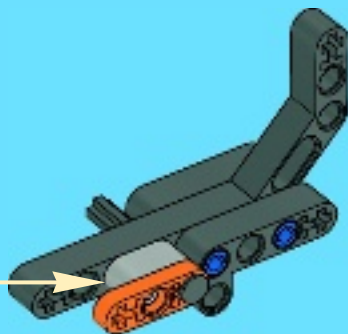
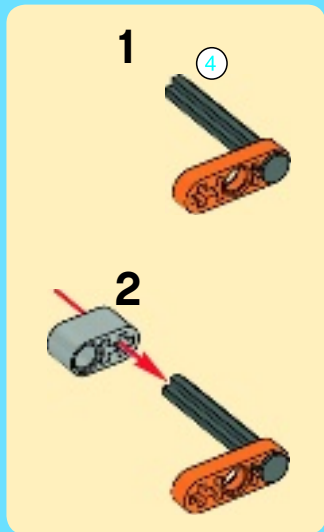

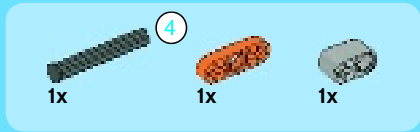

4

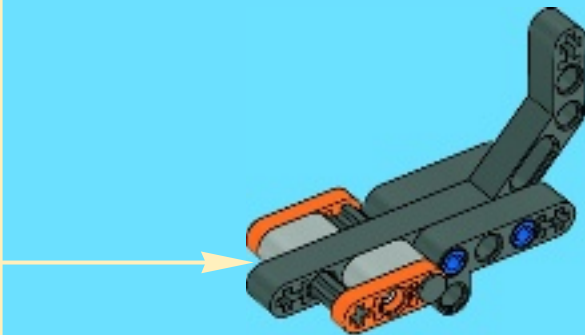
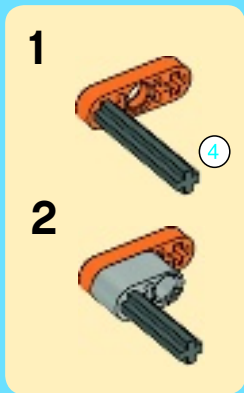

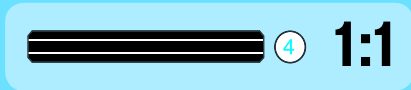
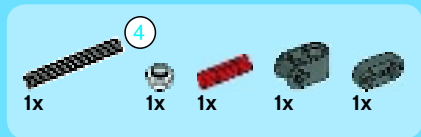

5

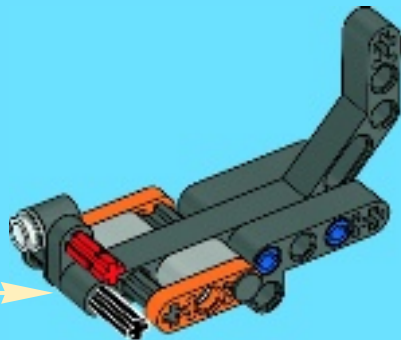
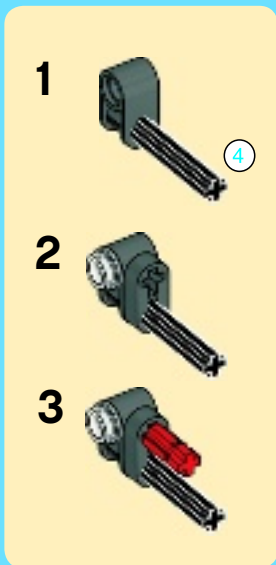



6

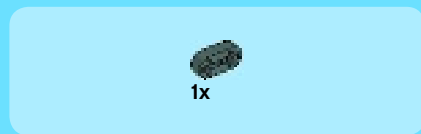
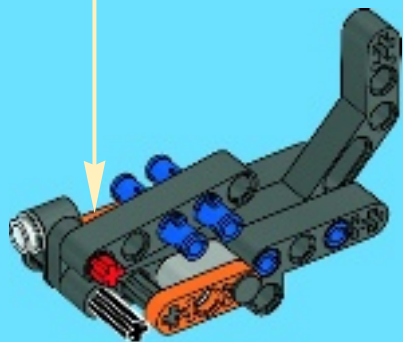
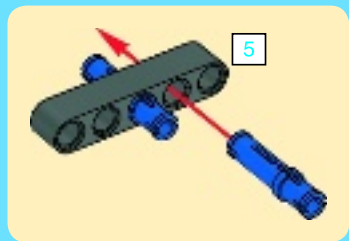

7

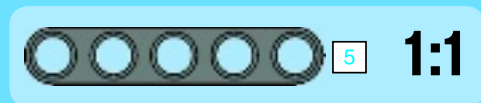
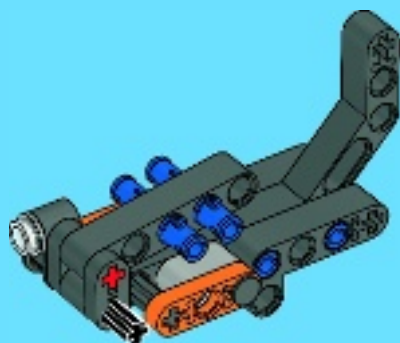



1x



1x

8

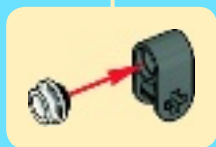
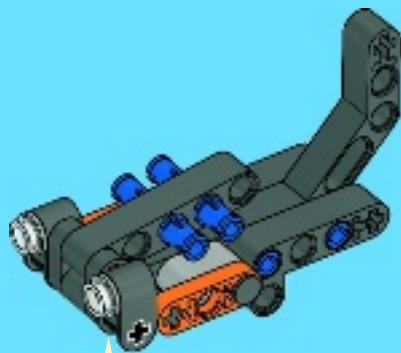

26



1x



1x

9

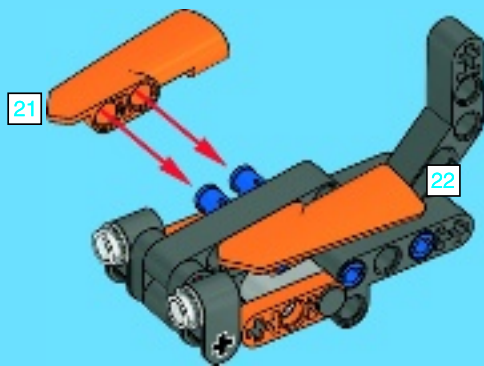

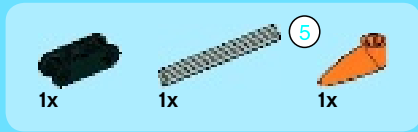

10

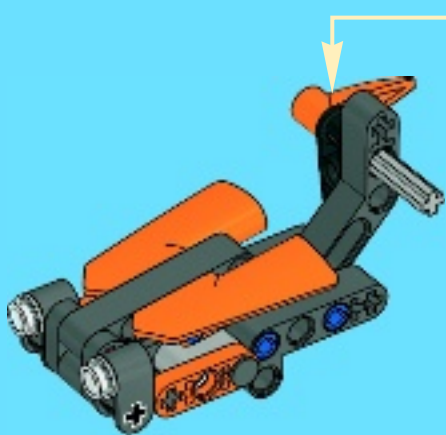
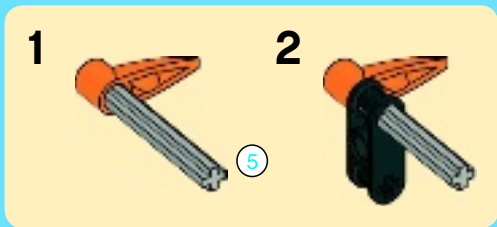

11

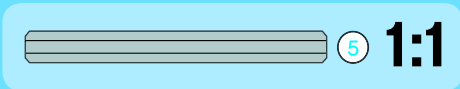
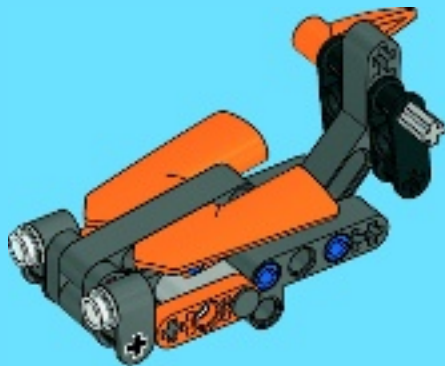



1x



1x



1x



1x

12

1



2



3

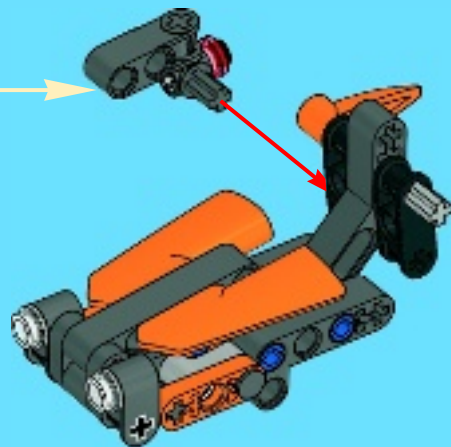

1x

1x

1x

1x

13

1

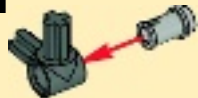

2



3

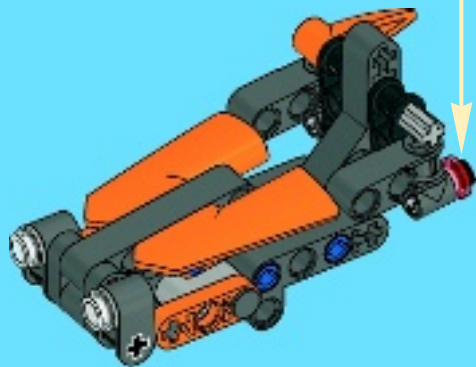

1x

14

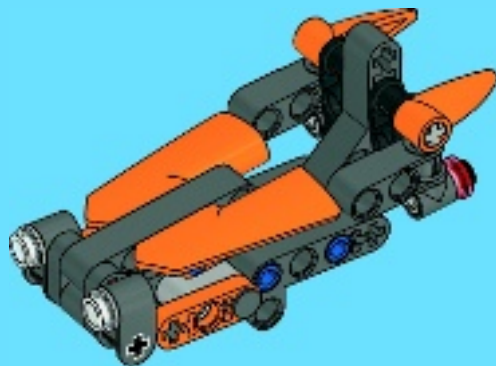



2x



2x

5

15

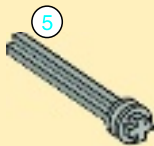

5

2x

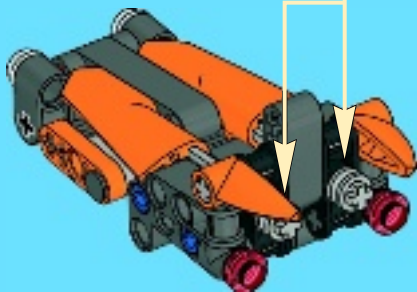

3



5

1:1

30



2x



1x

3

16



3

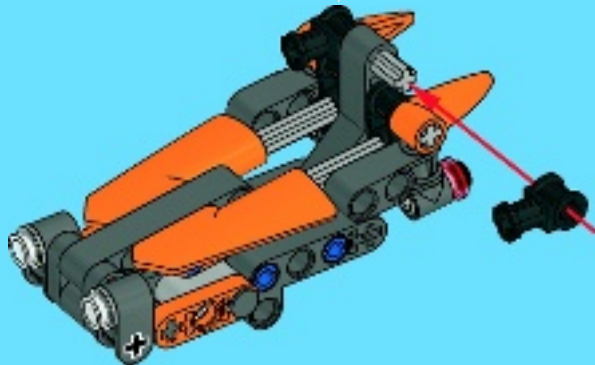



2x



4x



1x

17

1



2



3



18

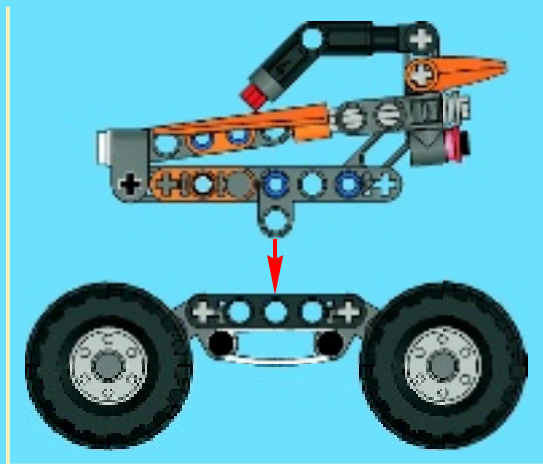
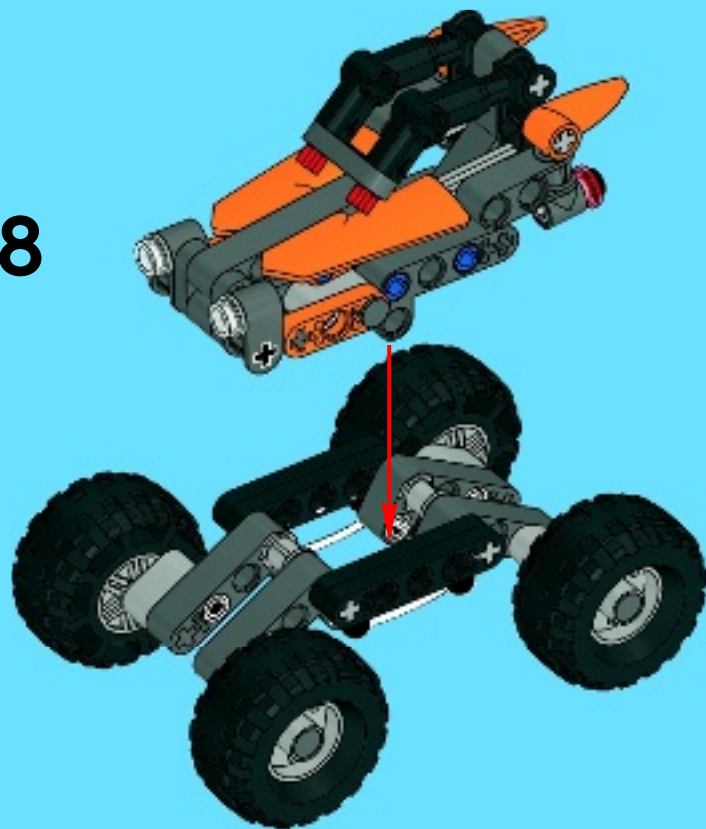

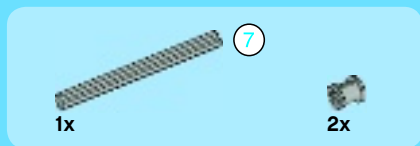

19

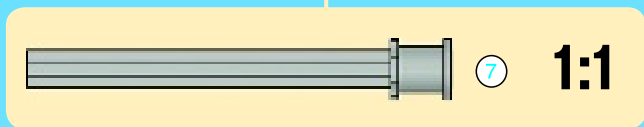
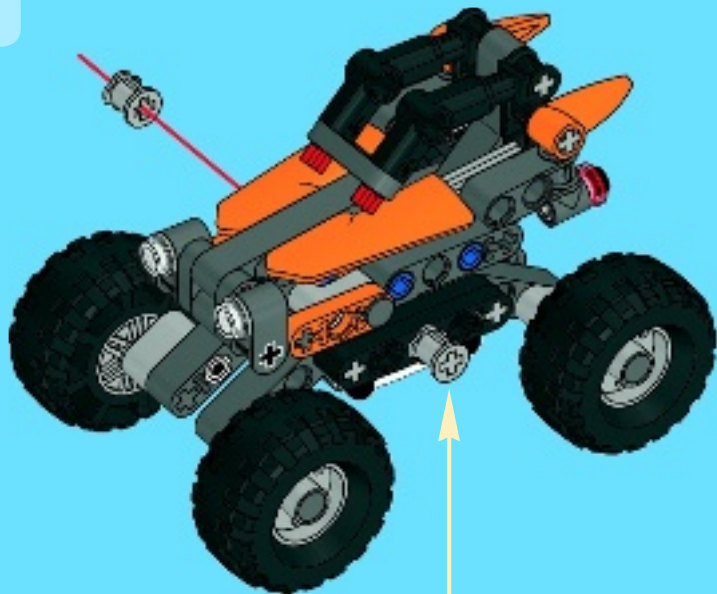

20





TECHNIC



LEGO.com/technic



WIN!

Go to www.LEGOsurvey.com/product to fill out a survey for a chance to win a cool LEGO® Product.

No purchase necessary.

Open to all residents where not prohibited.



www.LEGOsurvey.com/product

GEWINNE!

Nimm an der Umfrage auf www.LEGOsurvey.com/product teil und hab die Chance ein cooles LEGO® Produkt zu gewinnen!

Die Teilnahme am Gewinnspiel führt zu keinerlei Kaufverpflichtungen. Teilnahme in allen nicht ausgeschlossenen Ländern möglich.

WIN!

Ga naar www.LEGOsurvey.com/product, vul een enquêteformulier in en maak kans op een cool LEGO® product.

Geen aankoopverplichting. Iedereen mag deelnemen, uitgezonderd ingezetenden van landen waar een enquêteverbod geldt.

GAGNE!

Visite www.LEGOsurvey.com/product pour répondre à un questionnaire et avoir une chance de gagner un produit LEGO® très cool!

Aucune obligation d'achat. Ouvert à tous les résidents des pays autorisés.

当てよう!

www.LEGOsurvey.com/product にアクセスして、アンケートにご記入ください。当選者にはレゴ®製品を差し上げます。

お買い上げの必要はありません。禁止されていない限り、すべての皆様にご利用いただけます。



LEGO.com

6042920 / 6042921

LEGO and the LEGO logo are trademarks of the/son des marques de commerce de/son marcas registradas de LEGO Group. ©2013 The LEGO Group.