



# IDEAS

40487





# IDEAS



I am a research scientist and engineer but have always been drawn by artistic creativity and aesthetics. I think that is why my passion of toy photography and LEGO® models is such a great match. My passion for building with LEGO bricks, combined with toy photography, makes me feel like an artist telling stories through my models and photos. My entry to the LEGO Ideas competition was also inspired by a story of an adventure that my wife and I still have to experience. We have done a lot of traveling and living abroad, but we have never had the opportunity to go on a sailboat and set sails for the horizon. The sailboat is named “Éloïse” after our daughter, so this is really a celebration of us as a family, which makes it so much more than just a sailboat to me: it’s a dream-come-true, like a perfect holiday. Whenever I look

at my model on my desk, I begin to dream of cruising around exotic destinations, to the sound of the ocean and the dolphins playing around the sailboat. These are the stories that I want to tell with my models, and I am just so happy and honored that this exact story received so much support from the community. I am so proud of winning the competition, because when you are doing something so important to you, you easily doubt your own skills and ideas. There are so many great builders out there in the community, so it was quite intimidating submitting an entry for the first time. I could not have done this without my wife's support, feedback and inspiration, so without her, I am not sure I would ever have entered the competition. My best piece of advice for any builder of tomorrow, who wants to join a LEGO Ideas competition, is to find a concept and hold on to it. When working with

a creative challenge, too often people start over instead of refining and improving the initial concept they felt inspired by. Show and share your work with friends and family, because you will need their feedback, ideas, knowledge and inspiration, to create something that is truly meaningful and impressive. And when doing something that you are truly proud of, it is also important to have someone to share it with.

*Yan Chevalier, LEGO® Ideas Fan competition Winner,  
Toy Photographer and LEGO Enthusiast*



# IDEAS



Je suis chercheur scientifique et ingénieur, mais j'ai toujours été attiré par la créativité artistique et l'esthétique. Je crois que c'est pour cette raison que ma passion pour la photographie de jouets et les modèles LEGO® font si bon ménage. Ma passion pour la construction avec des briques LEGO, combinée avec la photographie de jouets, me fait sentir comme un artiste qui raconte des histoires à travers ses modèles et ses photos. Ma contribution au concours LEGO Ideas a également été inspirée par l'histoire d'une aventure que ma femme et moi n'avons pas encore vécue. Nous avons beaucoup voyagé et vécu à l'étranger, mais nous n'avons jamais eu l'occasion d'embarquer à bord d'un voilier et de mettre les voiles. Le voilier porte le nom de notre fille, « Éloïse », donc c'est une véritable célébration de notre famille, ce qui en fait bien plus qu'un

voilier pour moi : c'est un rêve devenu réalité, comme des vacances idylliques. Chaque fois que je regarde mon modèle sur mon bureau, je commence à rêver de destinations exotiques, du son de l'océan et de dauphins folâtrant autour du voilier. Ce sont les histoires que je veux raconter avec mes modèles, et je suis tellement heureux et honoré que cette histoire précise ait reçu un tel soutien de la communauté. Je suis si fier d'avoir remporté le concours, car lorsque l'on réalise quelque chose qui nous est si cher, il est facile de douter de nos compétences et de nos idées. La communauté compte tellement de grands constructeurs, donc c'était assez intimidant pour moi de prendre part à la compétition pour la première fois. Je n'aurais pas pu le faire sans le soutien, la rétroaction et l'inspiration de ma femme; sans elle, je crois que je n'aurais jamais osé m'inscrire. Mon meilleur conseil pour les constructeurs de demain

qui désirent participer à un concours LEGO Ideas, c'est de trouver un concept et de s'y accrocher. Lors d'un défi créatif, les gens ont trop souvent tendance à tout recommencer au lieu de retravailler et de peaufiner le concept initial qui les a inspirés. Montrez votre travail à vos amis et à votre famille, car vous aurez besoin de leurs commentaires, de leurs idées, de leurs connaissances et de leur inspiration pour créer quelque chose de vraiment significatif et impressionnant. Et lorsque vous réalisez quelque chose dont vous êtes vraiment fier, il est important d'avoir quelqu'un avec qui le partager.

*Yan Chevalier, gagnant du concours d'amateurs LEGO® Ideas, photographe de jouets et passionné de LEGO*



# IDEAS



Soy investigador científico e ingeniero, pero siempre me siento atraído por la creatividad artística y la estética. Creo que es por eso por lo que mi pasión por la fotografía de juguetes y los modelos LEGO® da tan buen resultado. Mi pasión por construir con bricks LEGO, sumada a la fotografía de juguetes, me hace sentir como un artista que cuenta historias a través de sus modelos e imágenes. Mi participación en la competencia de LEGO Ideas está inspirada también en la historia de una aventura que mi esposa y yo tenemos aún pendiente por vivir. Hemos viajado mucho y pasado mucho tiempo viviendo en el extranjero, pero nunca hemos tenido la oportunidad de embarcarnos en un velero y navegar hacia el horizonte. El velero se llama Éloïse por nuestra hija, así que se trata de un verdadero homenaje a nuestra familia, lo

que hace que sea mucho más que un simple barco para mí: es un sueño hecho realidad; como unas vacaciones perfectas. Cada vez que miro el modelo en mi escritorio, empiezo a soñar con navegar hacia destinos exóticos, con el sonido del océano y los delfines jugando alrededor del velero. Esas son las historias que quiero contar con mis modelos, y me siento muy feliz y honrado de que esta, en particular, haya recibido tanto apoyo de la comunidad. Estoy muy orgulloso de haber ganado la competencia porque, cuando haces algo que es tan importante para ti, es fácil dudar de tus propias habilidades e ideas. Hay muchos constructores fantásticos en la comunidad, así que me intimidaba un poco presentar una solicitud por primera vez. No podría haber hecho todo esto sin el apoyo, los comentarios y la inspiración de mi esposa, así que, de no ser por ella, tal vez no hubiera llegado a participar en la competencia. Mi

mejor consejo para cualquier futuro constructor que quiera participar en una competencia de LEGO Ideas es que encuentre un concepto y se aferre a él. Al trabajar en un desafío creativo, la gente tiende con frecuencia a volver a empezar, en lugar de refinar y mejorar el concepto original por el que se sintieron inspirados. Hay que mostrar y compartir el trabajo con amigos y familiares porque se necesitan sus comentarios, ideas, conocimientos e inspiración para crear algo que sea realmente significativo e impresionante. Y, cuando haces algo de lo que te sientes realmente orgulloso, también es importante tener a alguien con quien compartirlo.

*Yan Chevalier, ganador de la competencia para fans de LEGO® Ideas, fotógrafo de juguetes y entusiasta de LEGO*

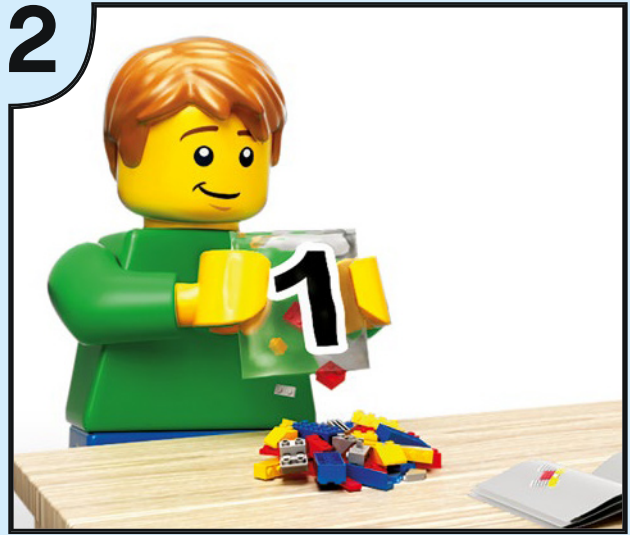



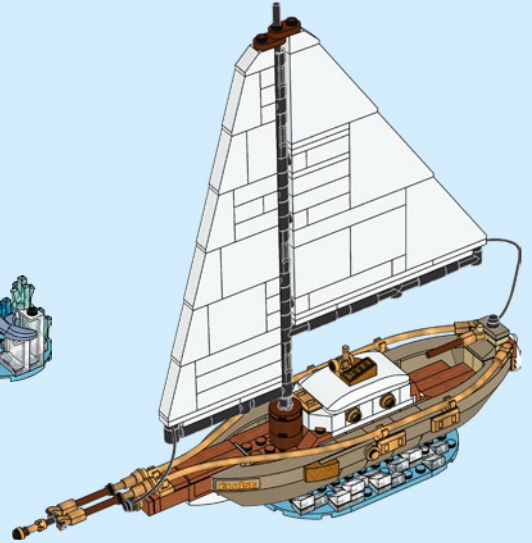
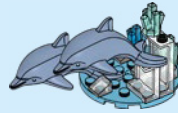
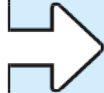
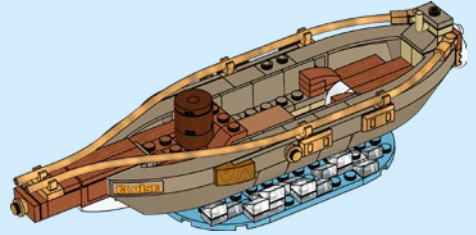
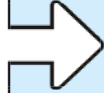



2x

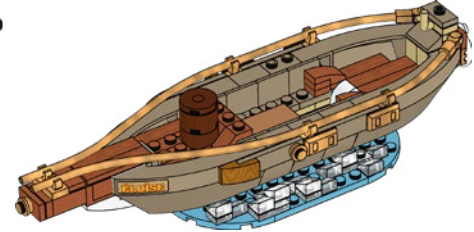
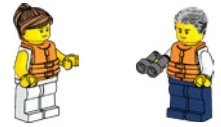
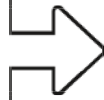

1

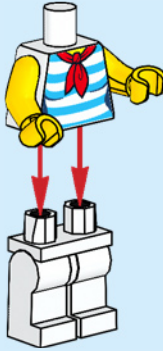

2

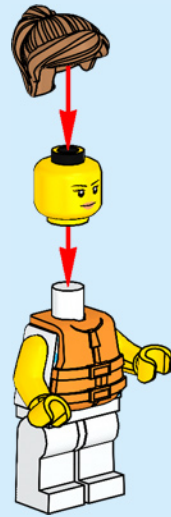

3



1

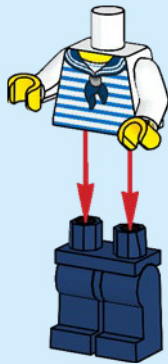

2

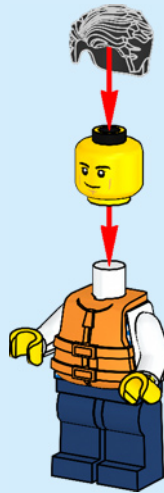

3



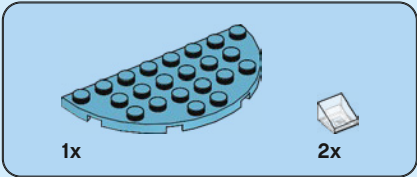

1

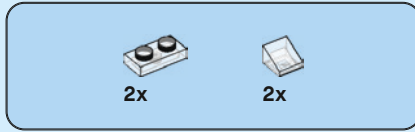
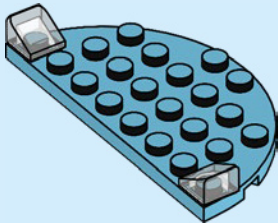

2

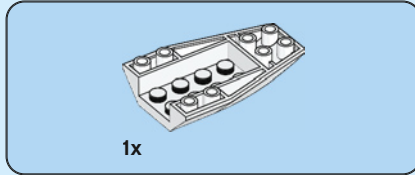
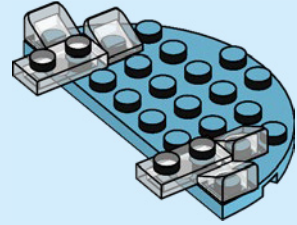

3

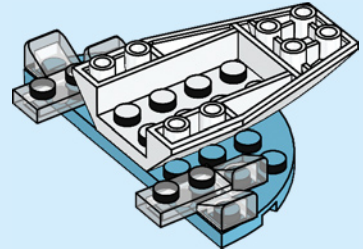

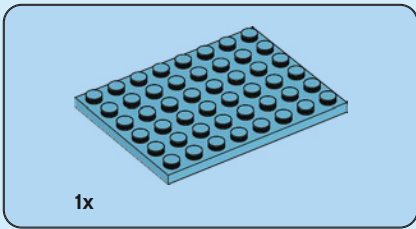

4

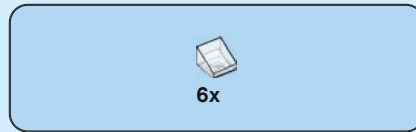
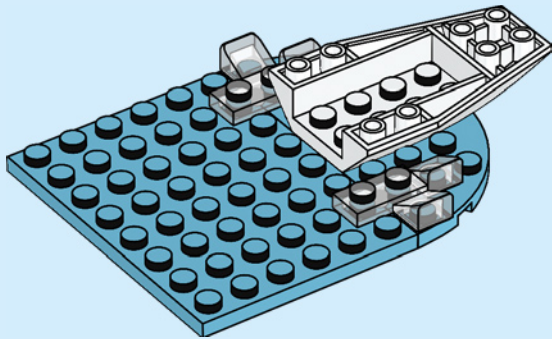

5

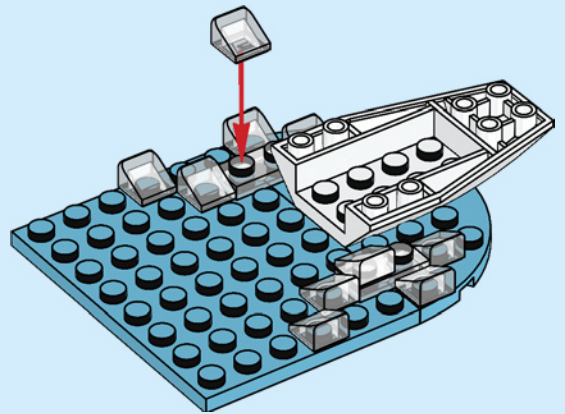

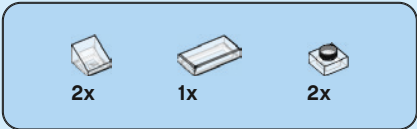

6

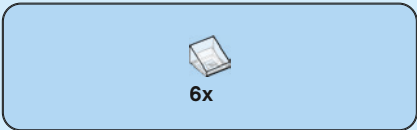
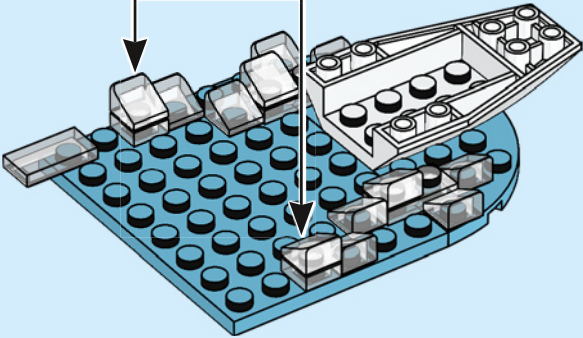
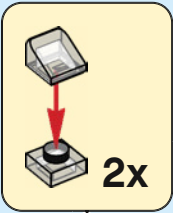

7

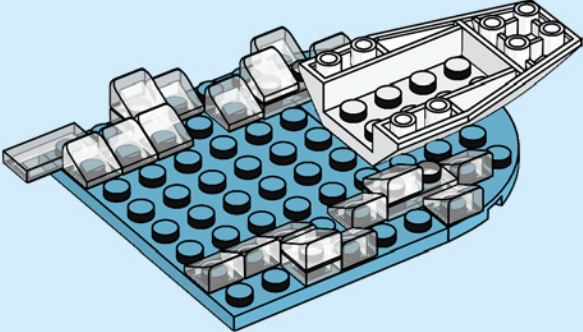

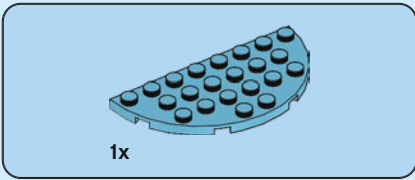

8

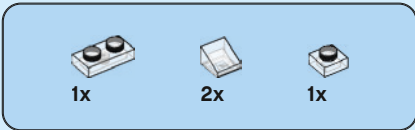
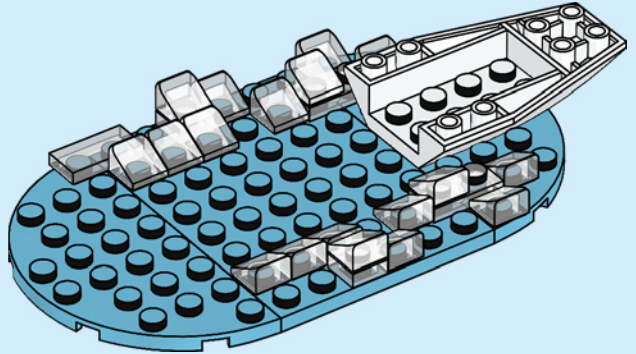

9

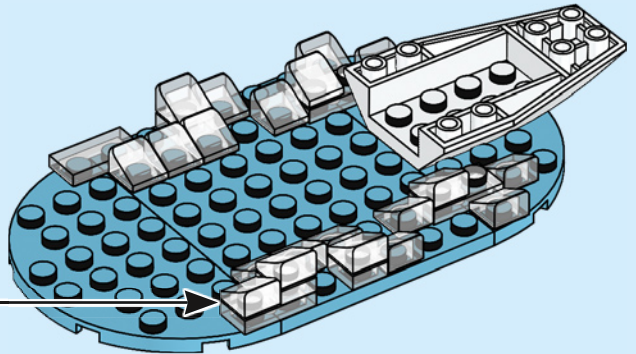
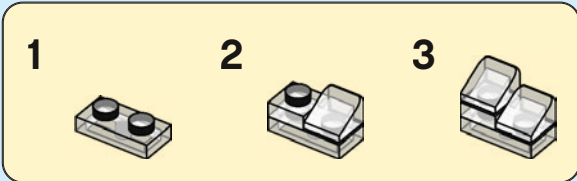



4x



2x

# 10

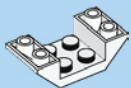
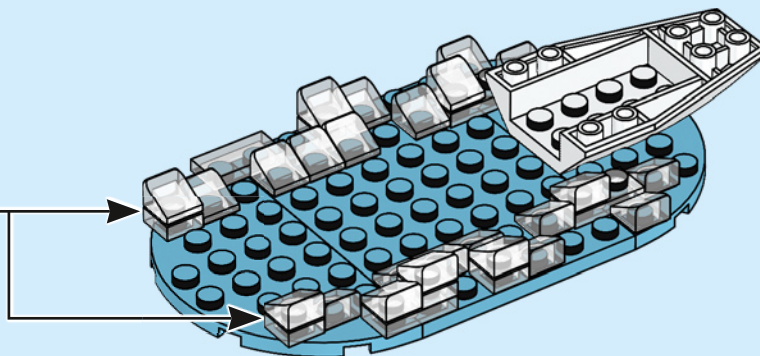
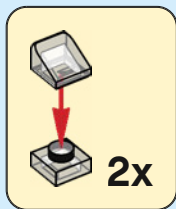

1x

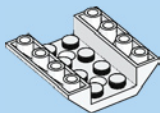

1x

# 11

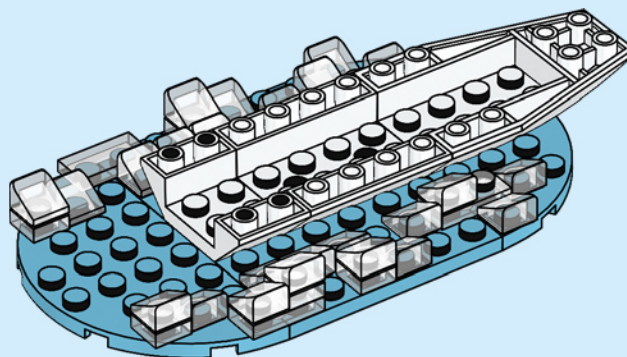



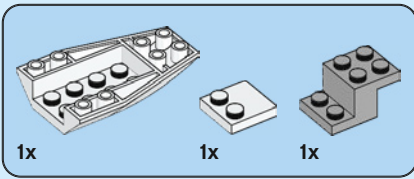

12

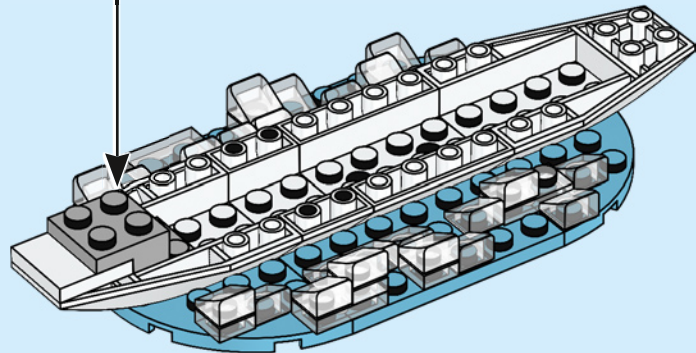
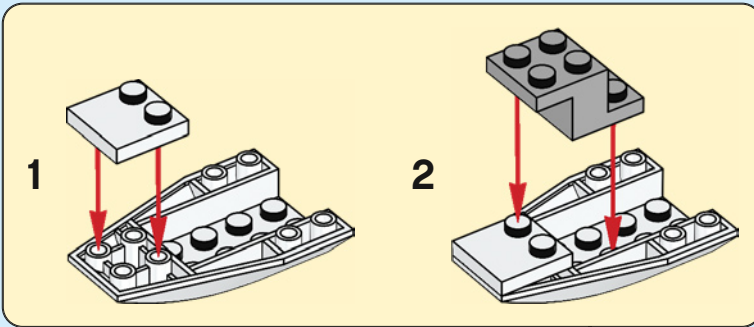

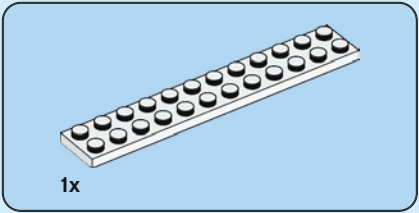

13

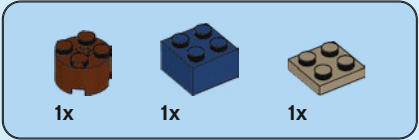
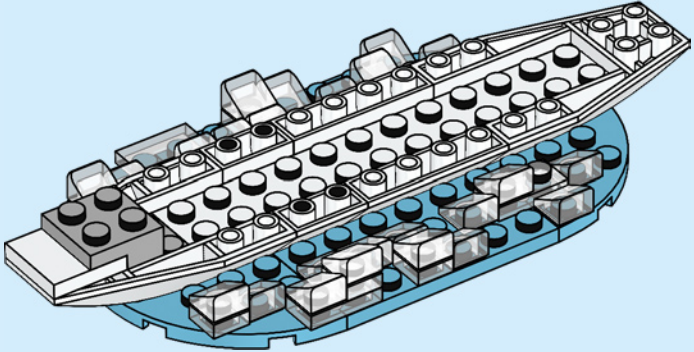

14

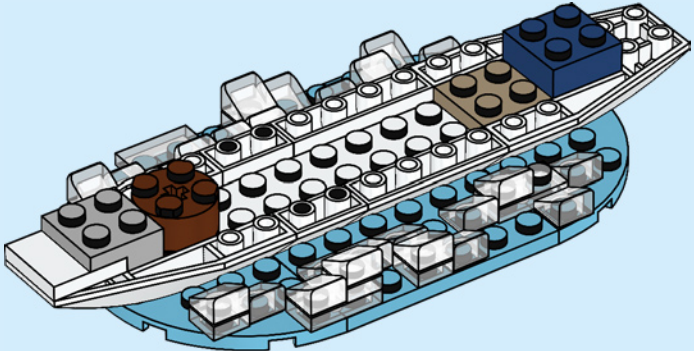

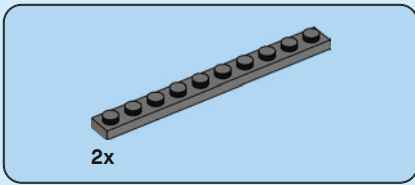

15

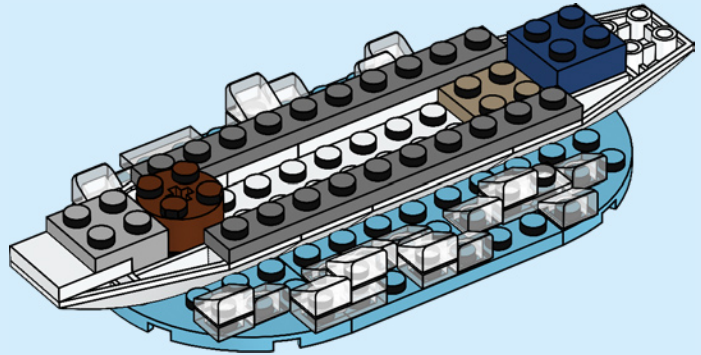

16

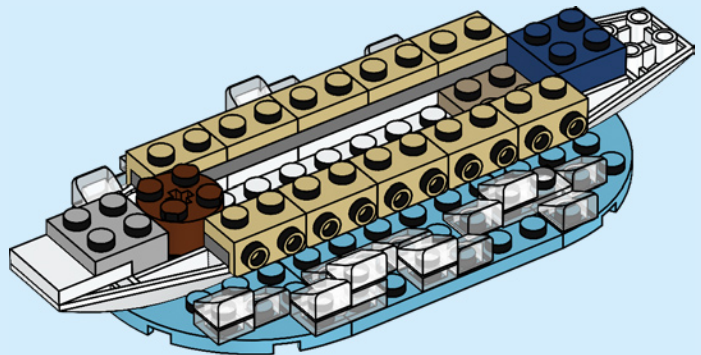

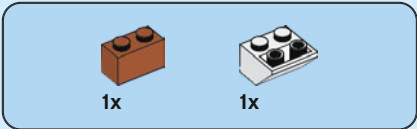

17

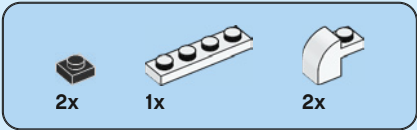
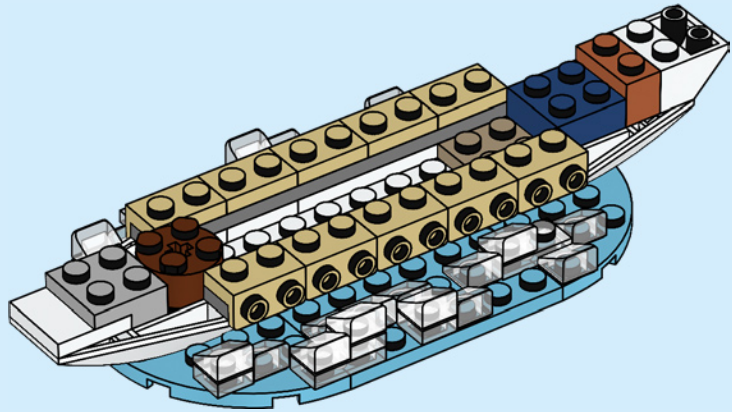

18

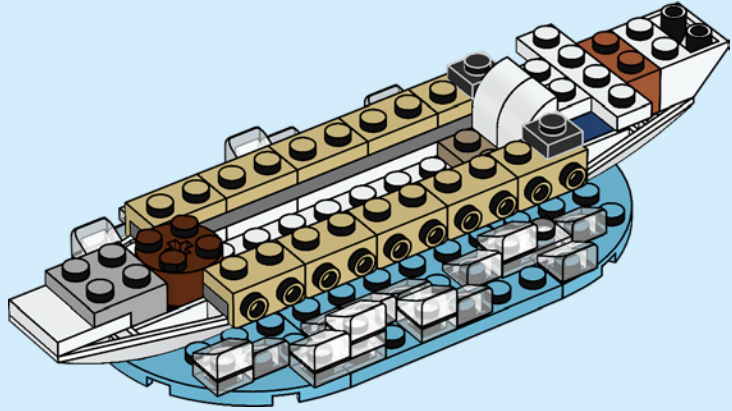

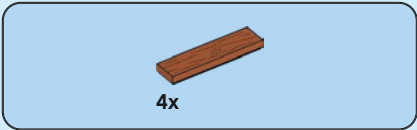

19

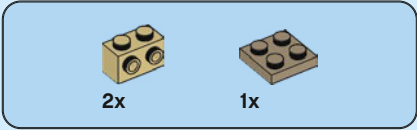
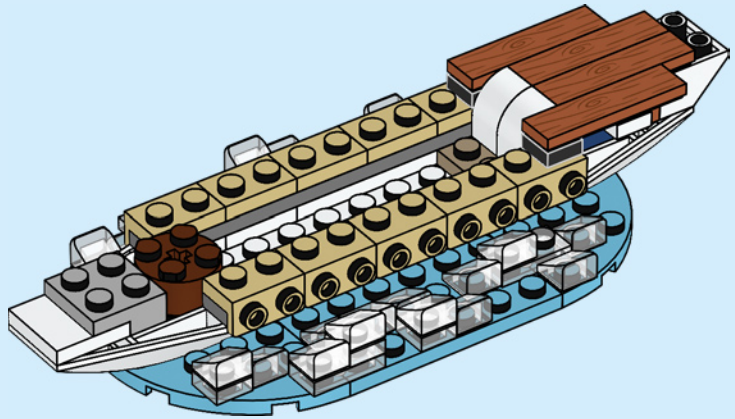

20

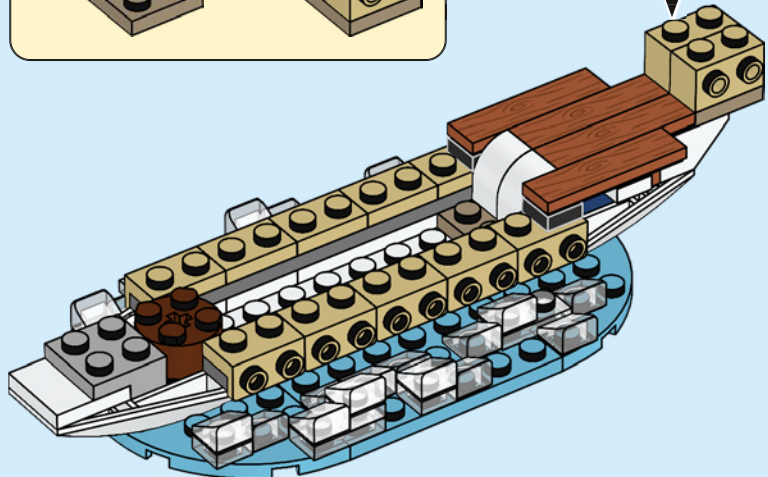
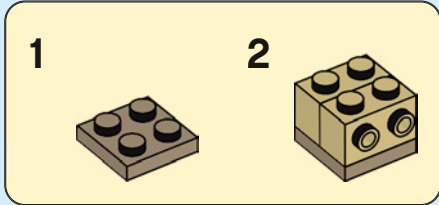



2x

21

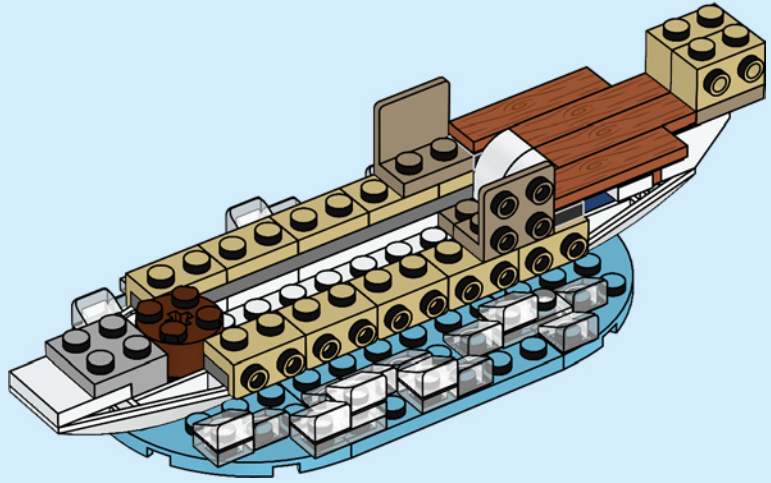

2x



4x

22

1



2



2x

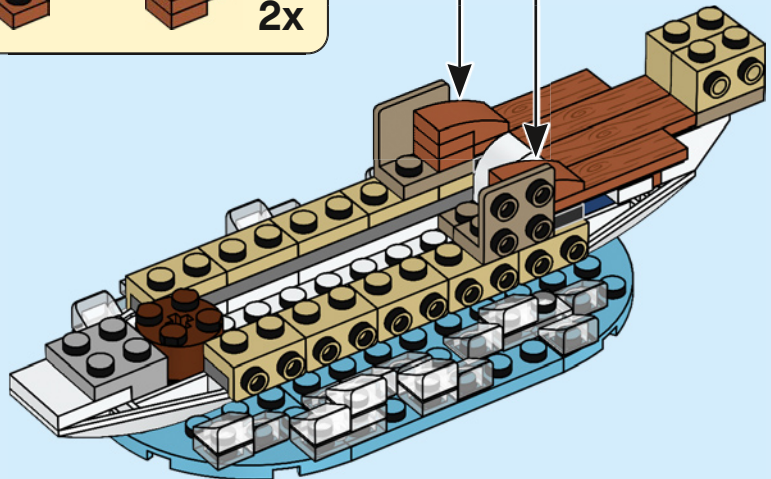



4x

# 23

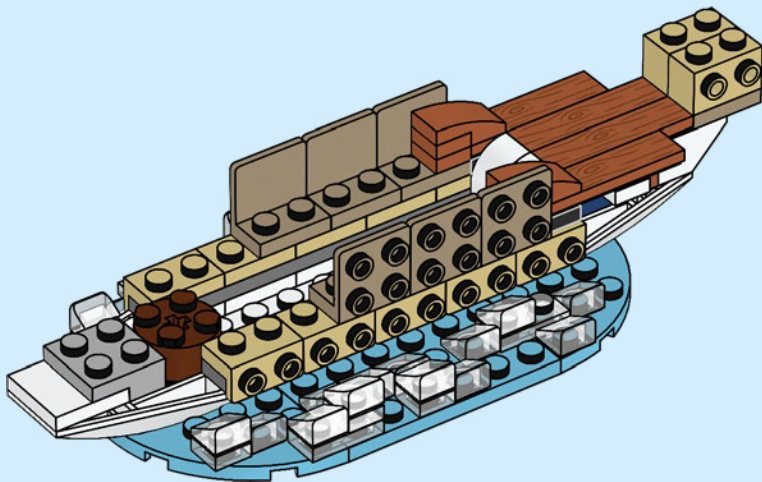

1x



1x

# 24

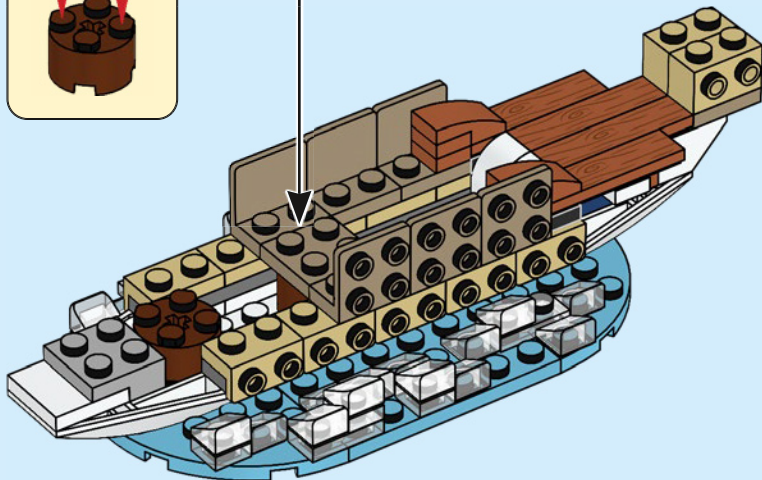
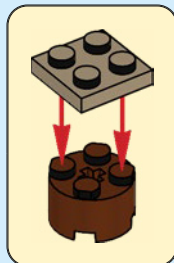



2x

25

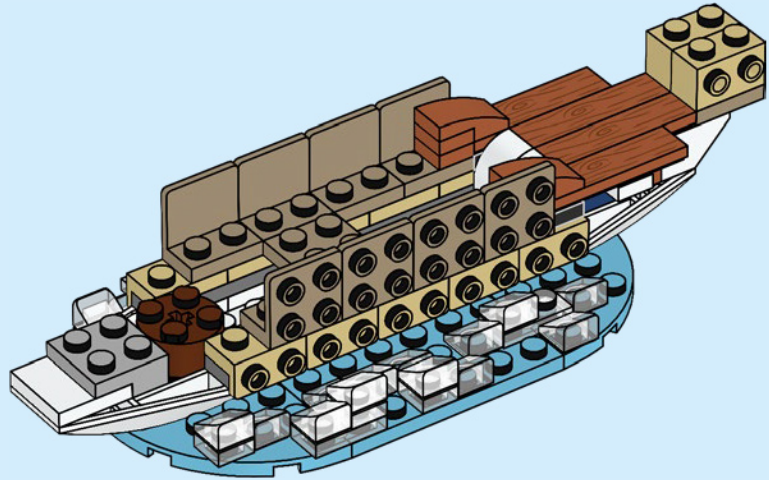

1x



1x

26

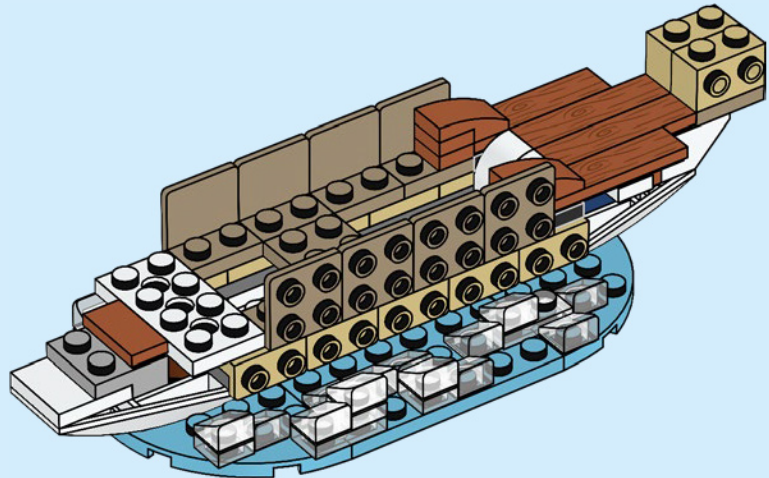



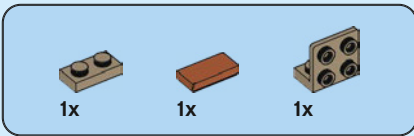

27

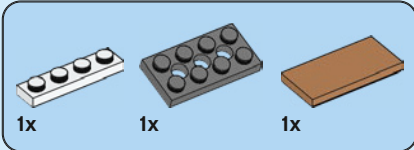
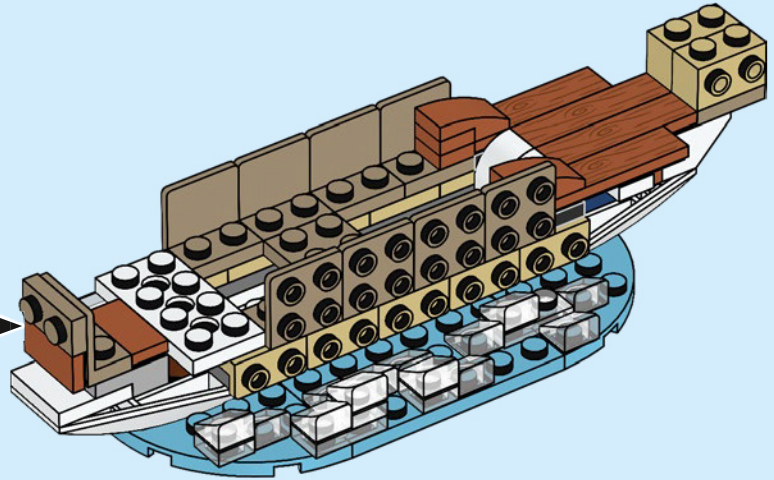
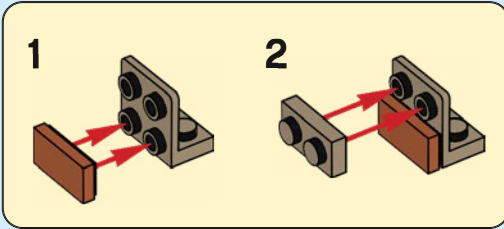

28

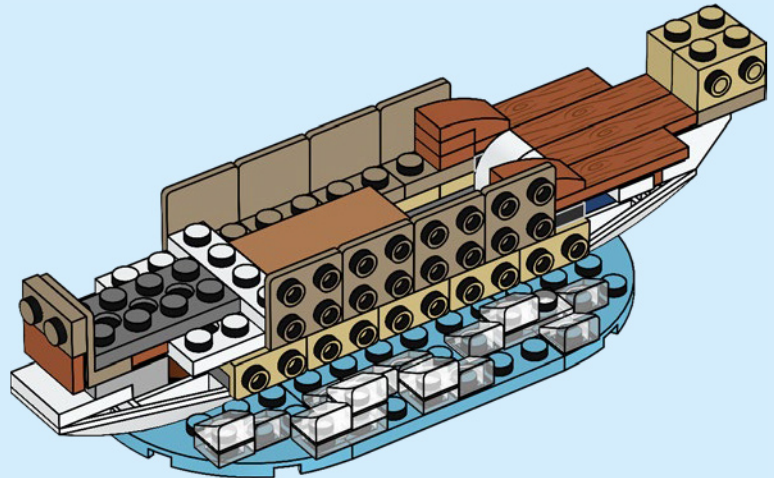

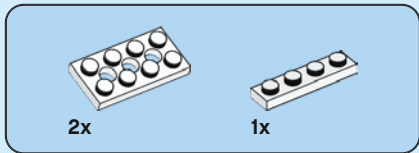

29

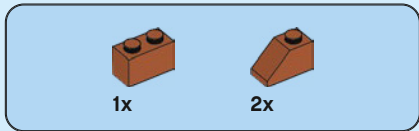
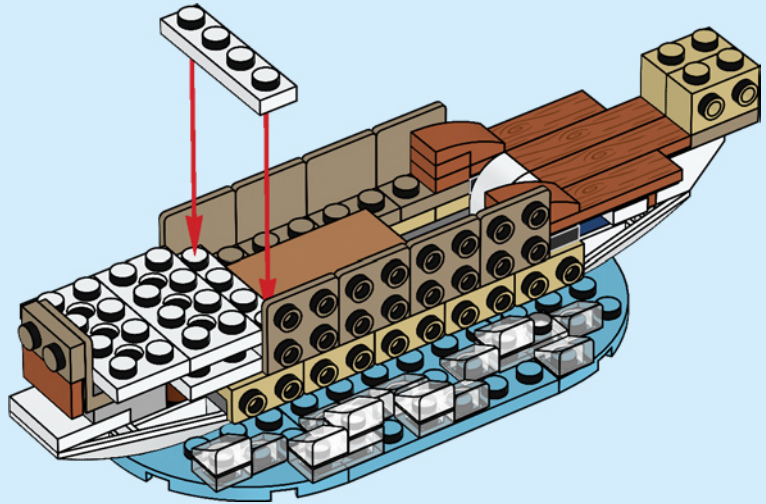

30

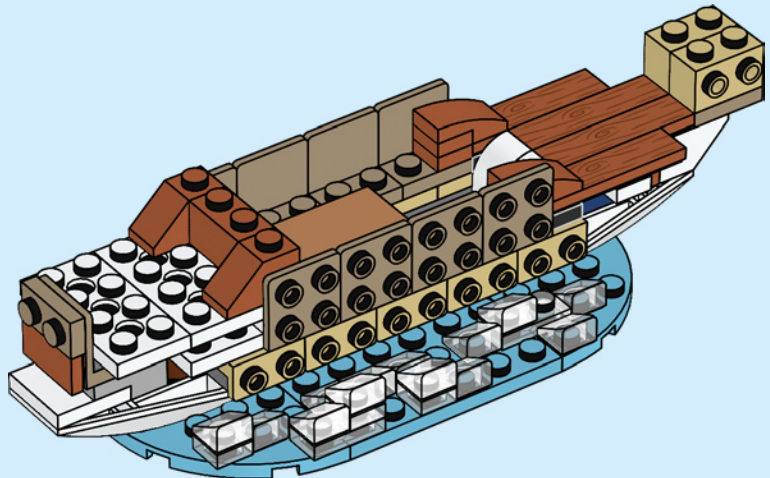



1x



2x

# 31

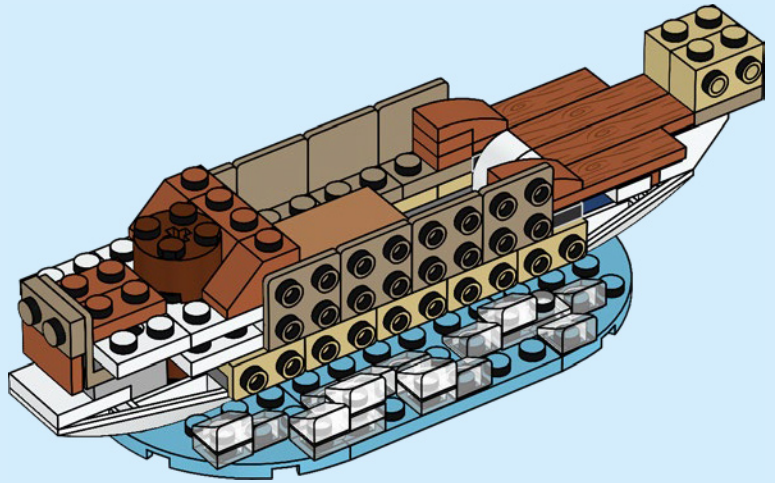

2x

# 32

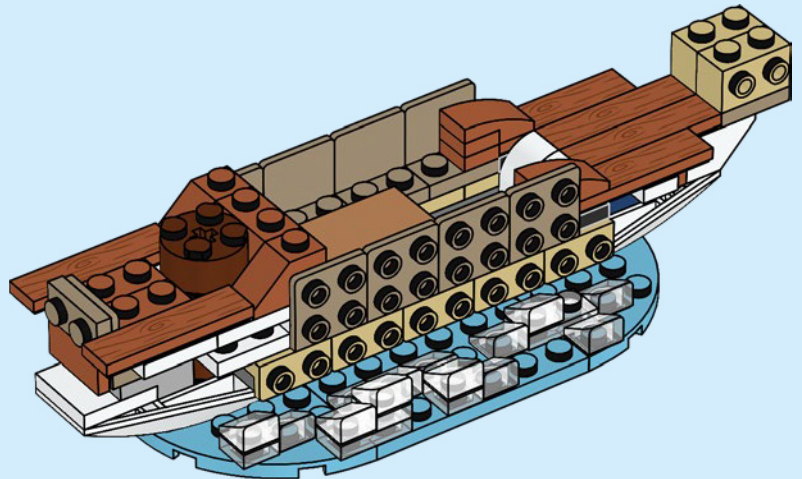

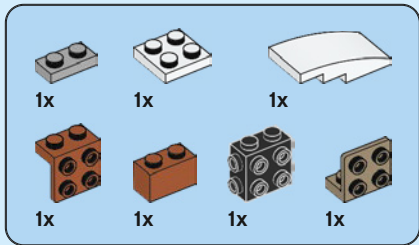

33

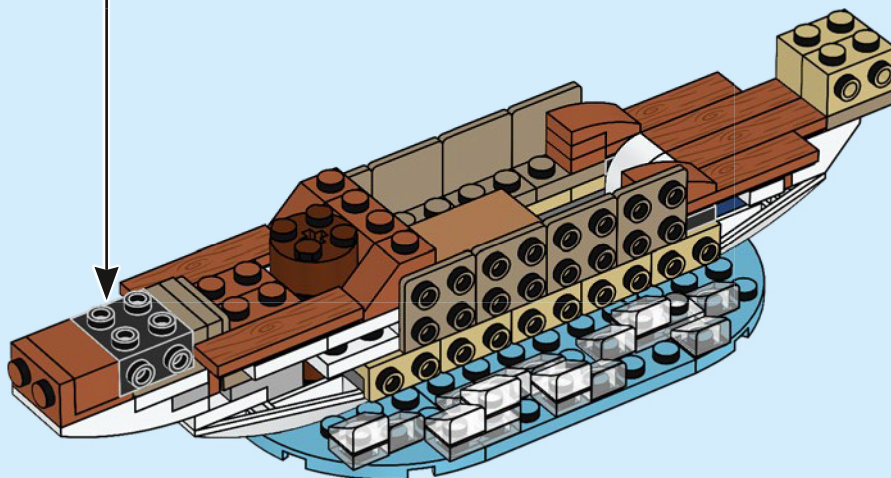
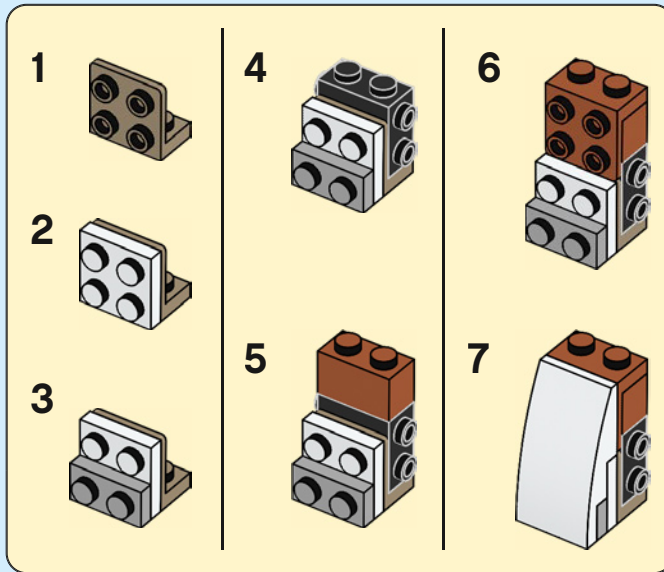

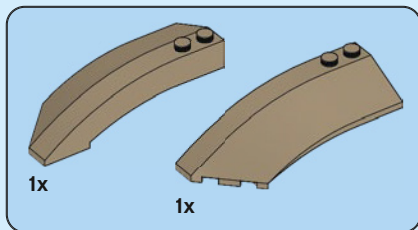

34

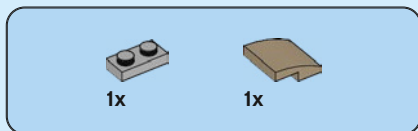
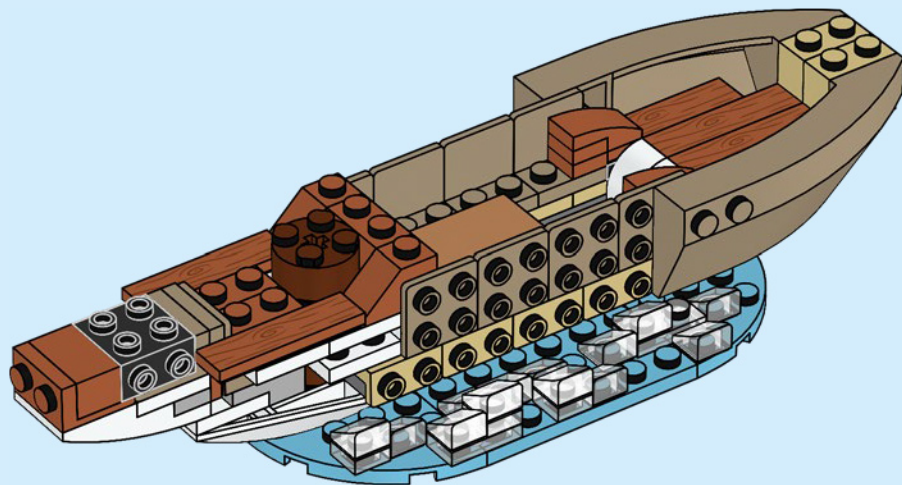

35

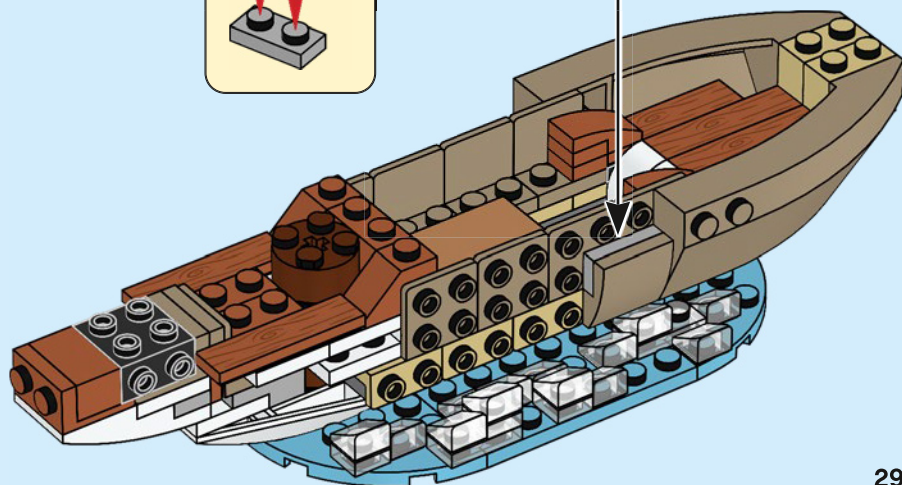
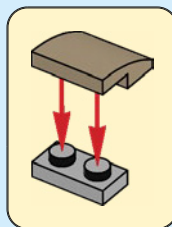

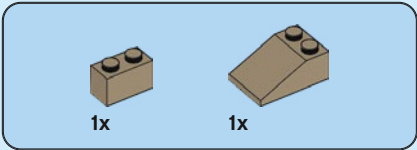

36

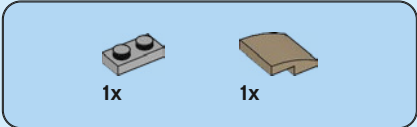
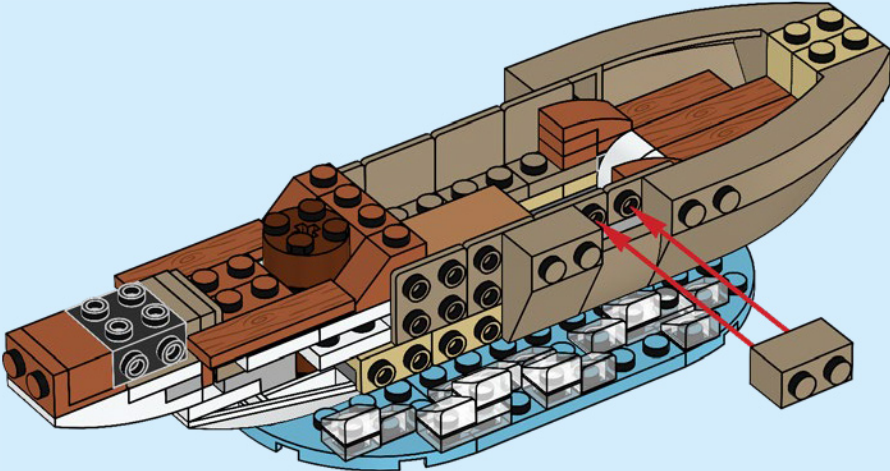

37

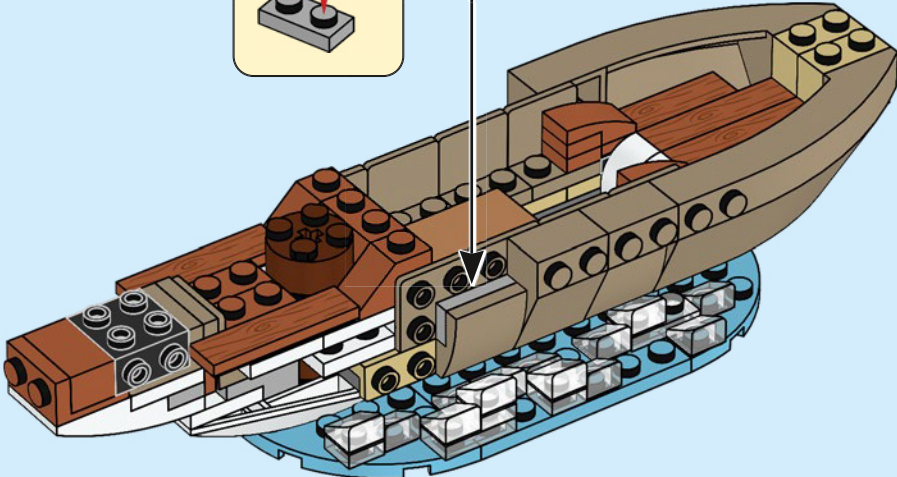
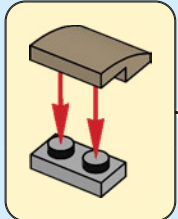

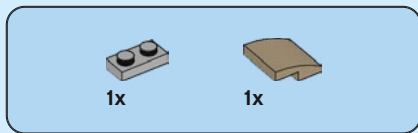

38

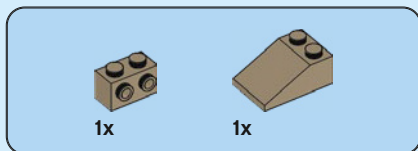
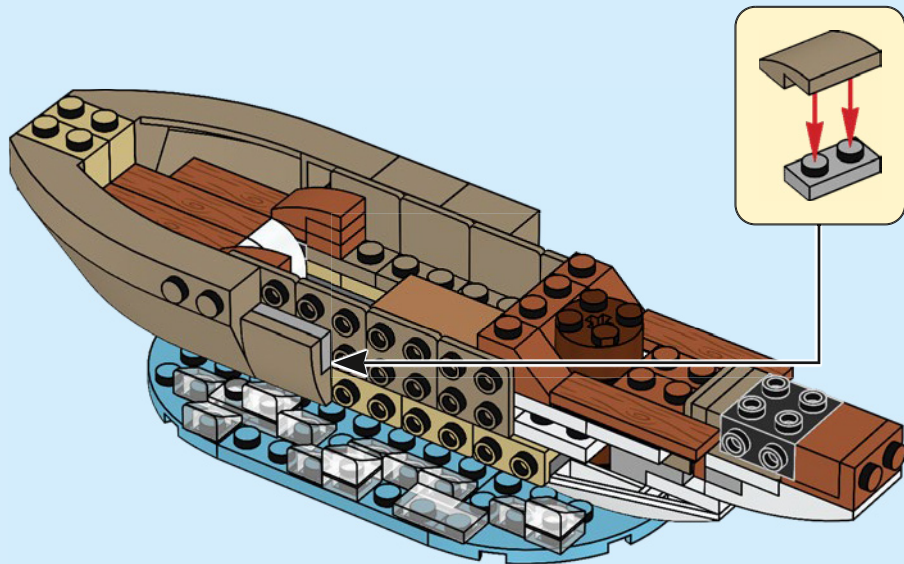

39

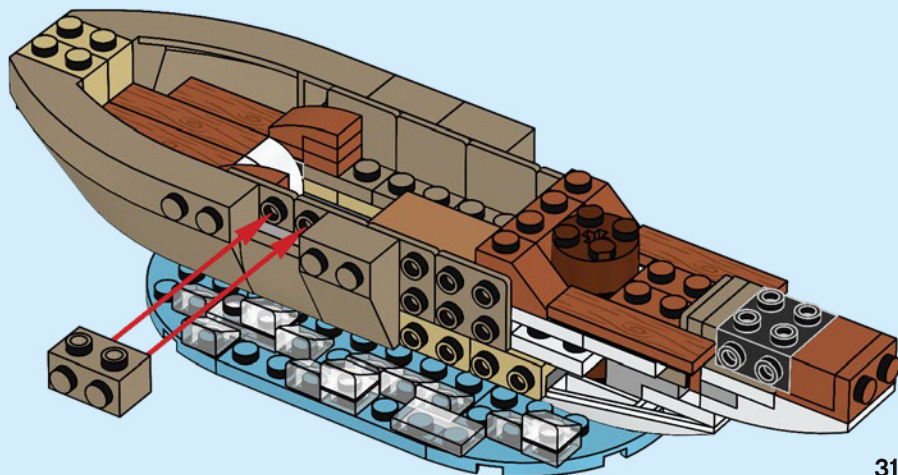

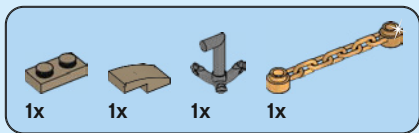

40

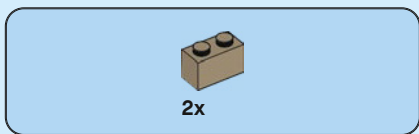
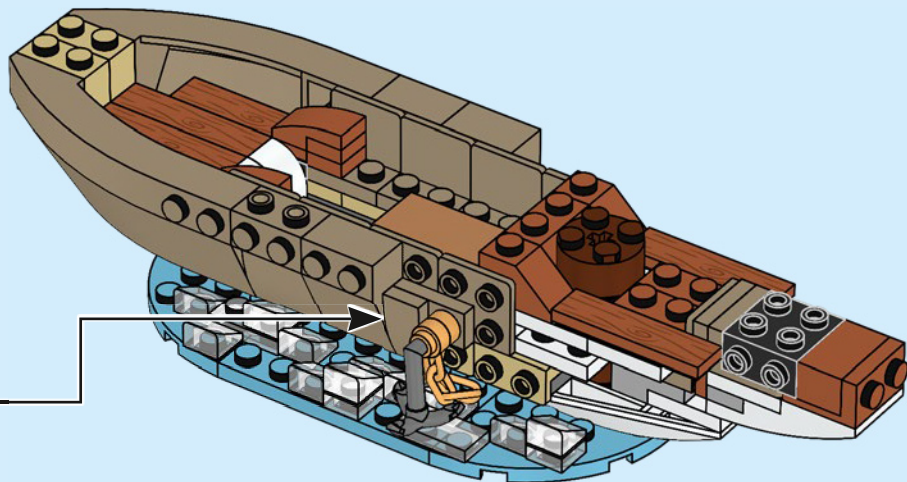
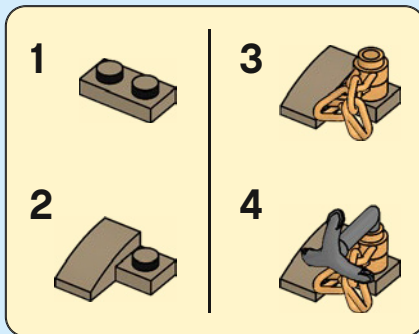

41

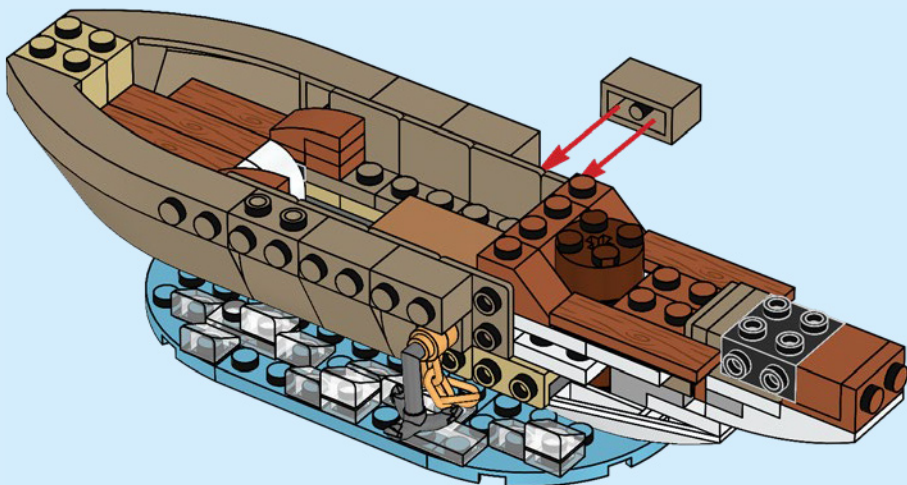



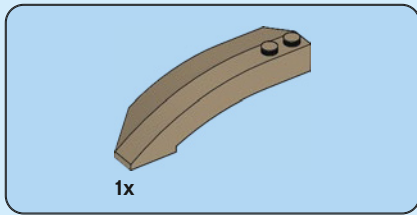

42

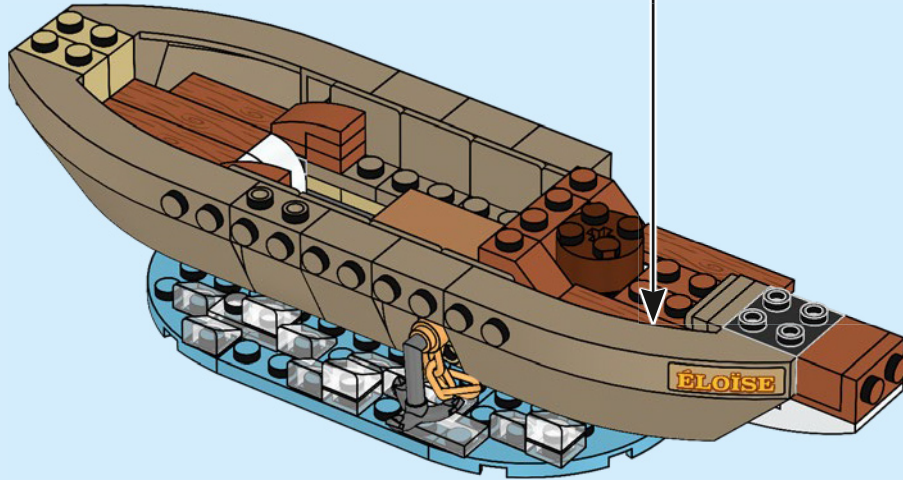
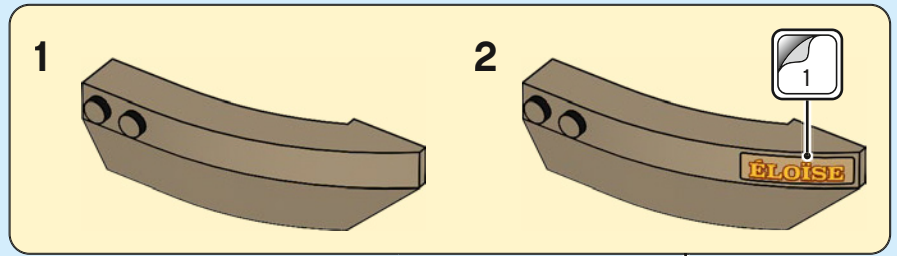

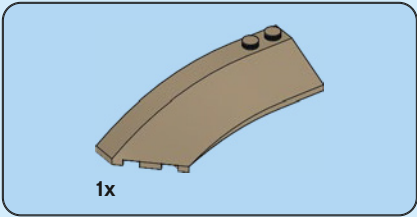

43

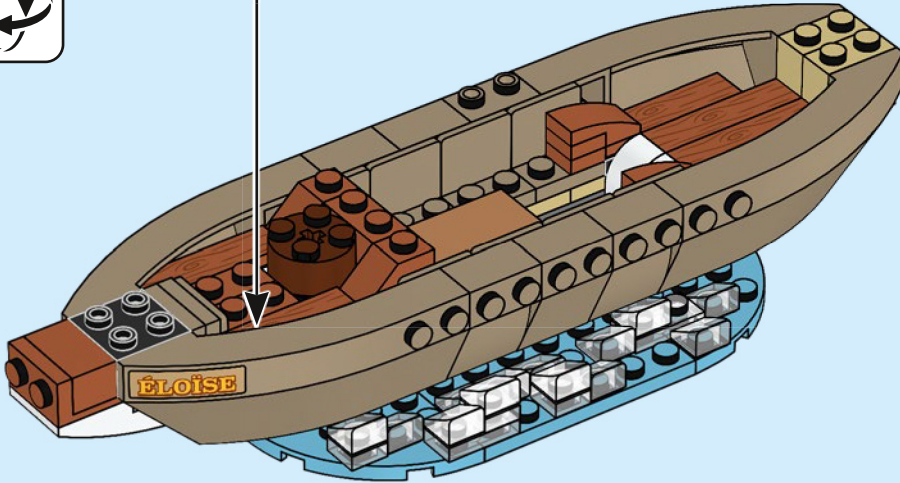
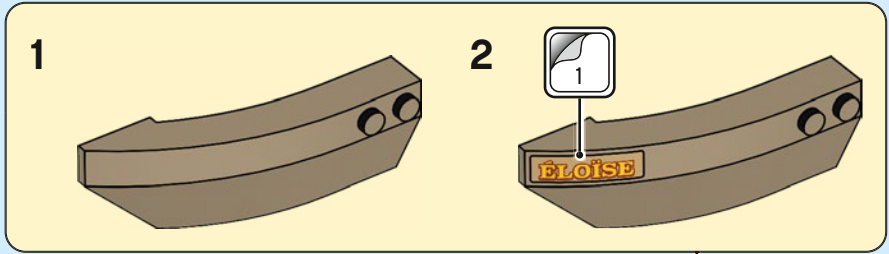

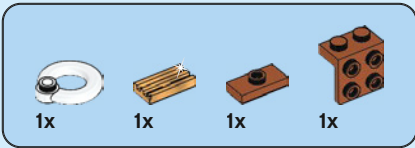

44

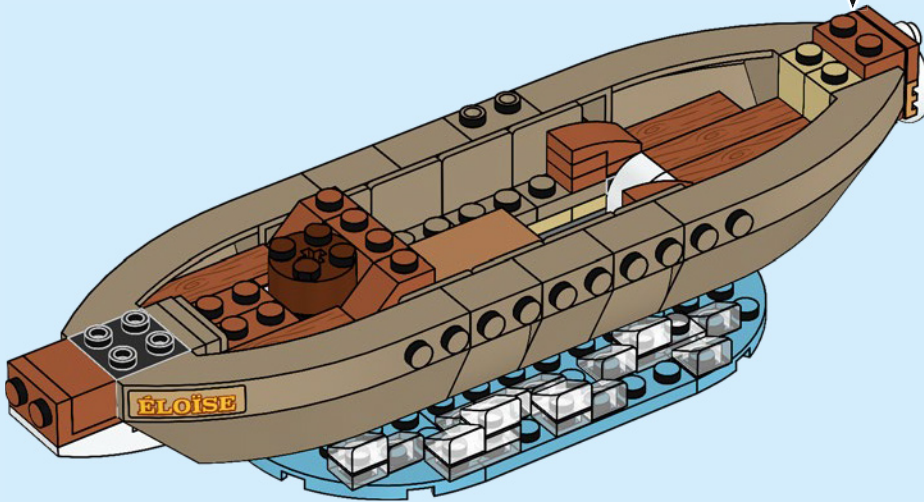
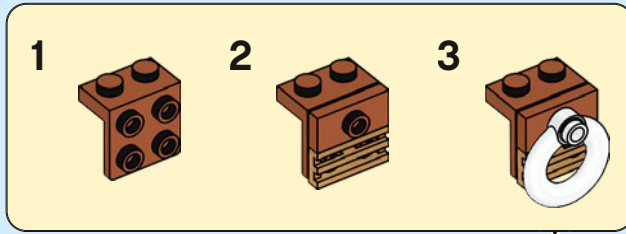



45

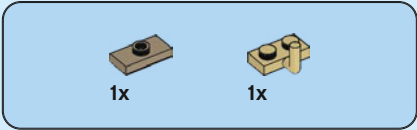
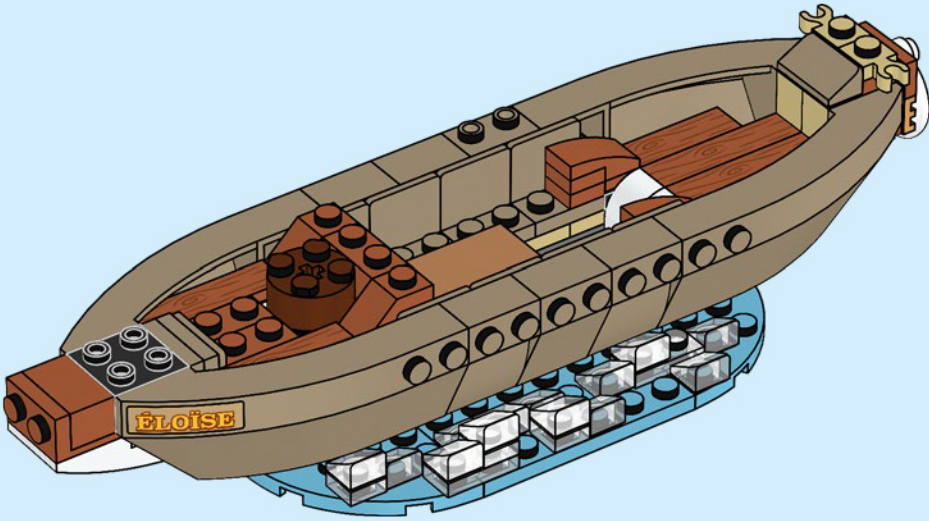

46

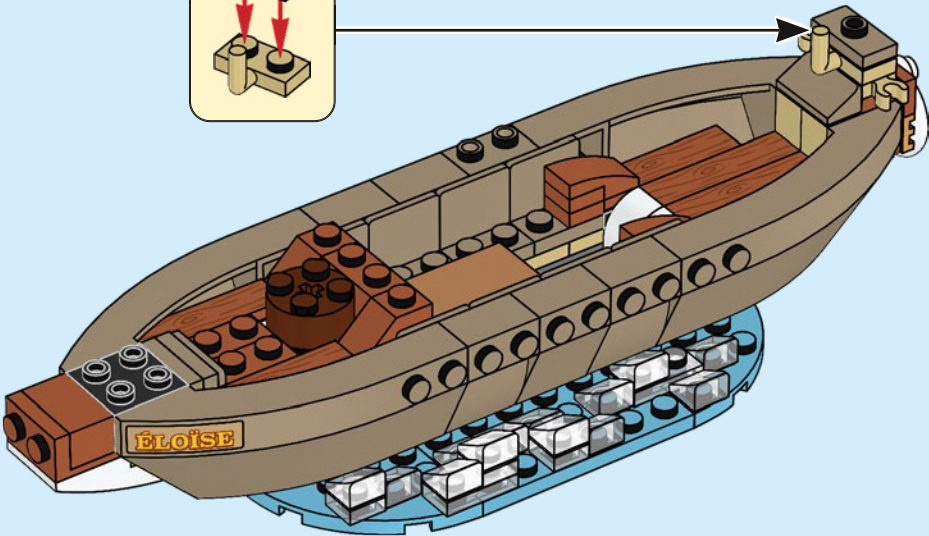
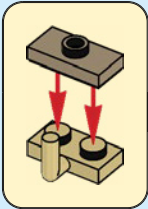

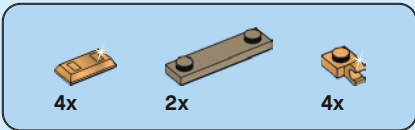

# 47

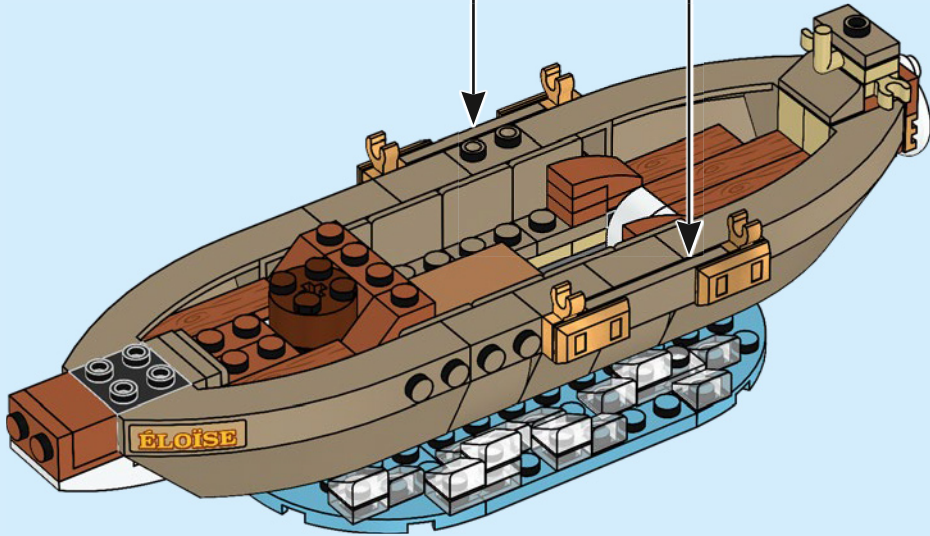
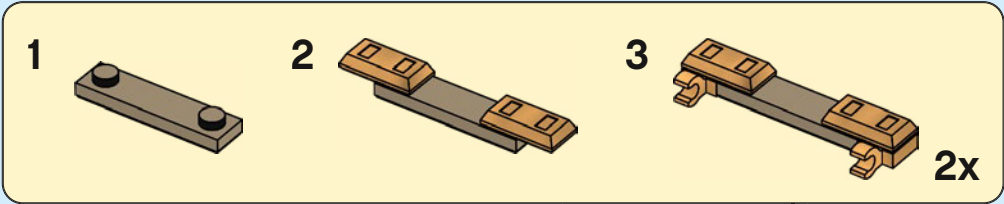

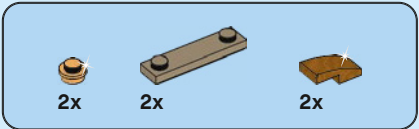

48

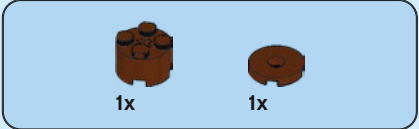
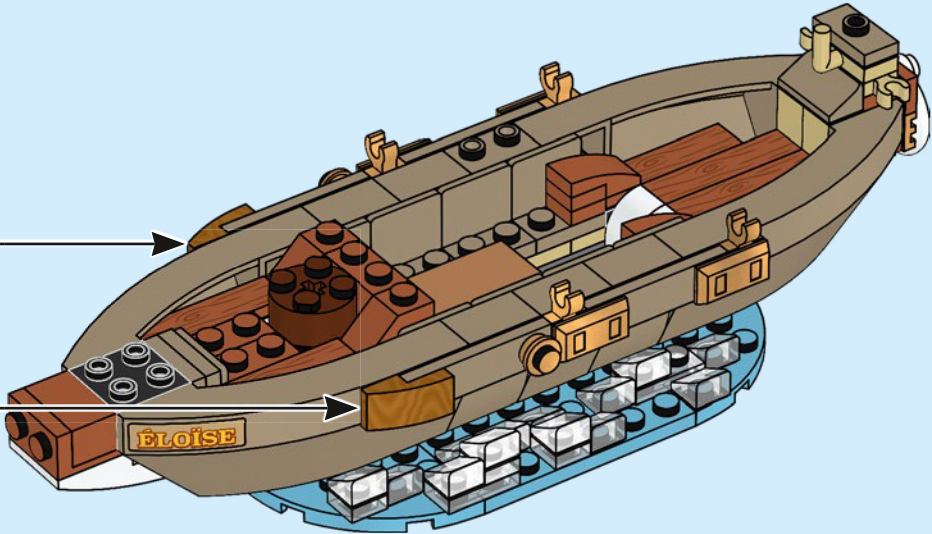
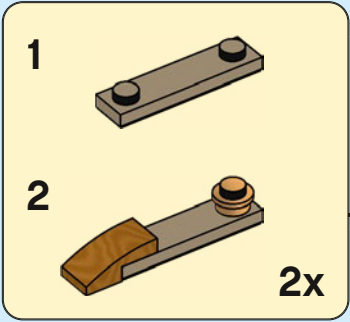

49

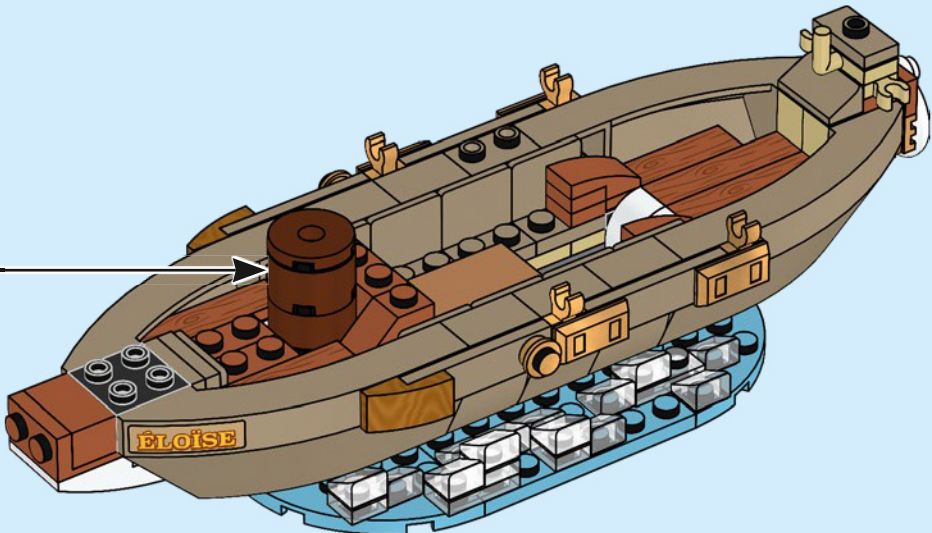
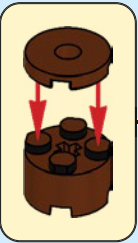

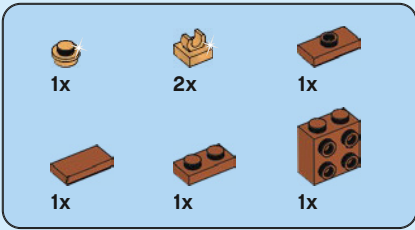

# 50

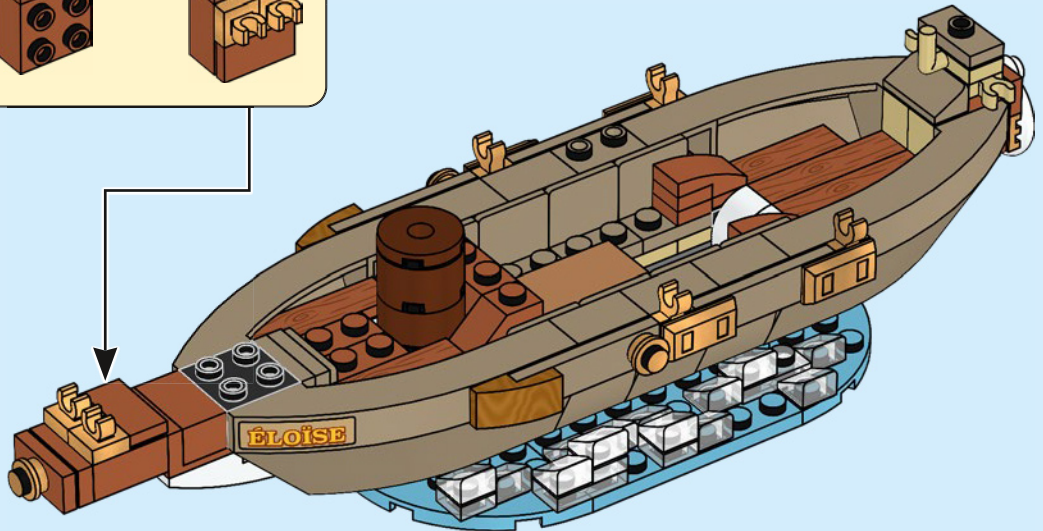
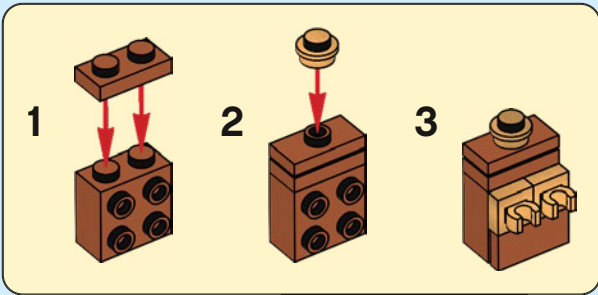



2x

51

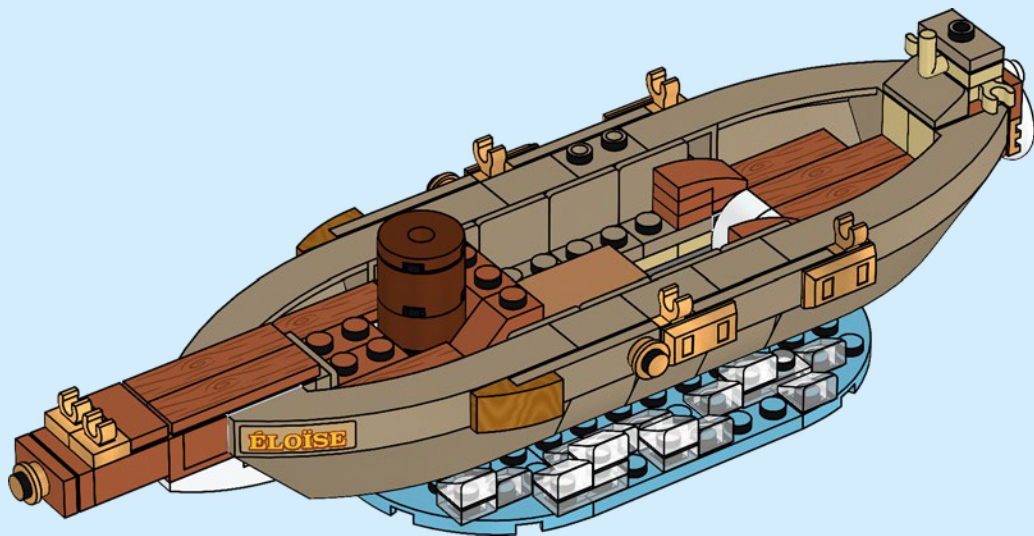



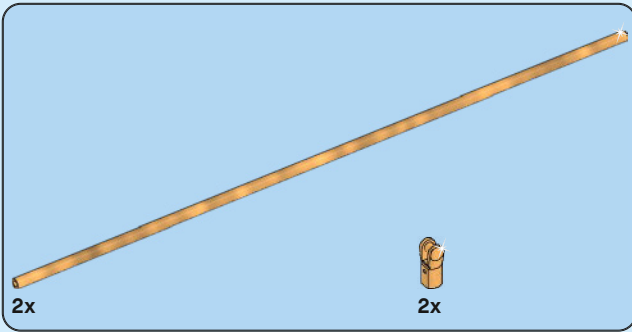

52

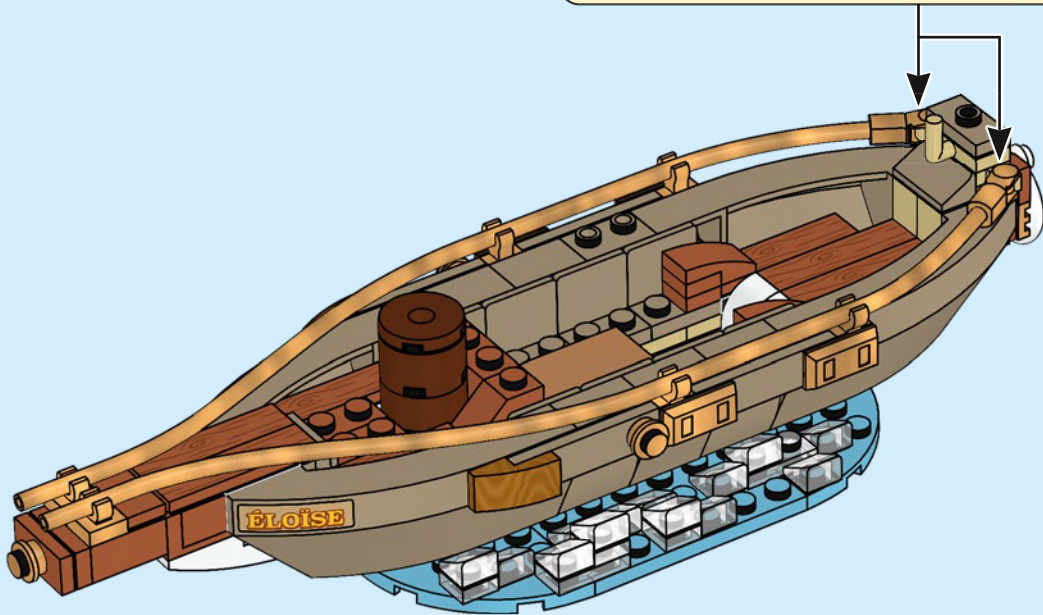
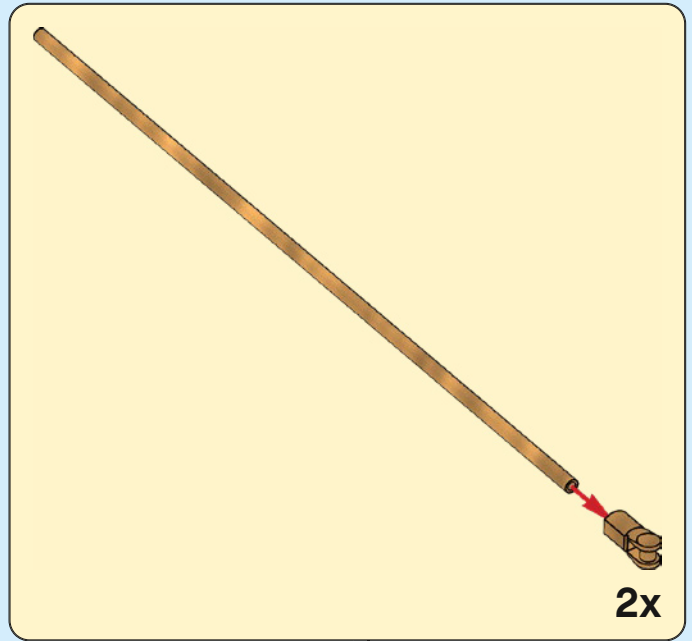

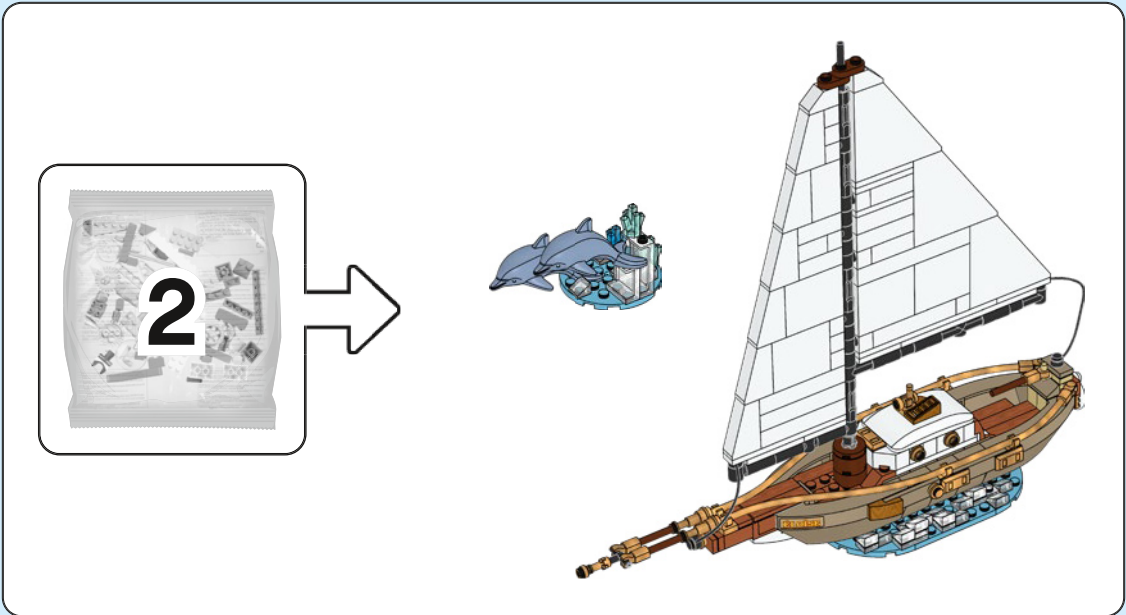

53

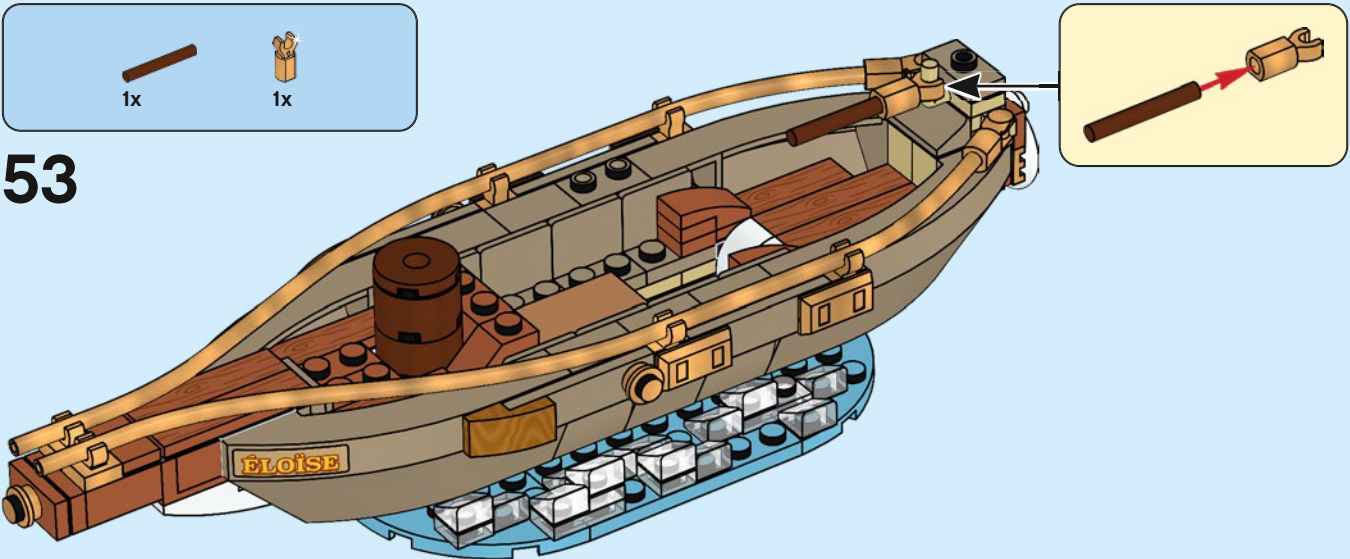

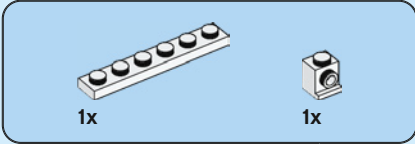
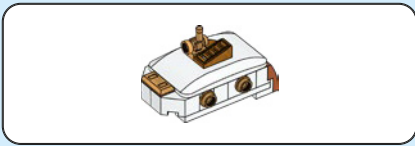

54

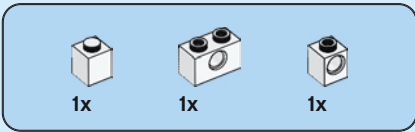
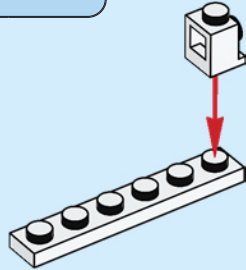

55

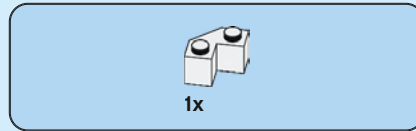
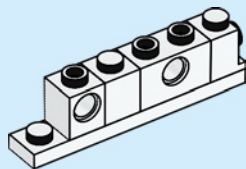

56

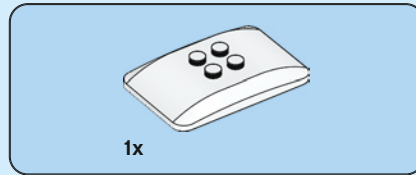
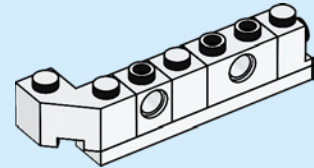

57

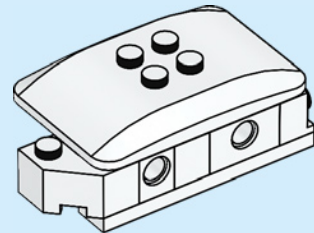



2x

# 58

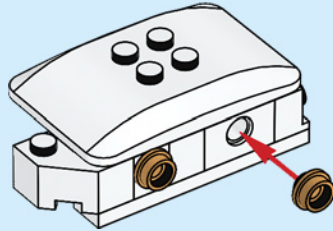

1x



1x



1x



1x



1x



1x

# 59

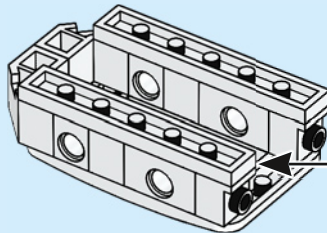

1

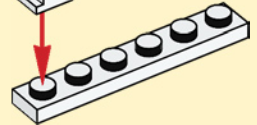

2

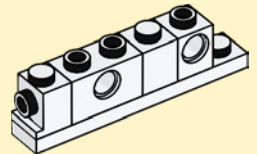

3

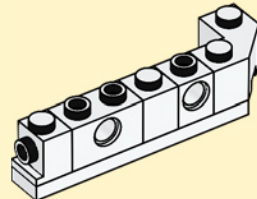



2x

60

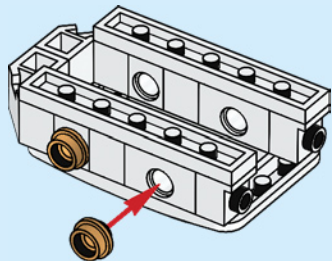

2x

61

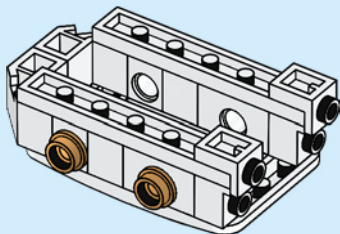

2x

62

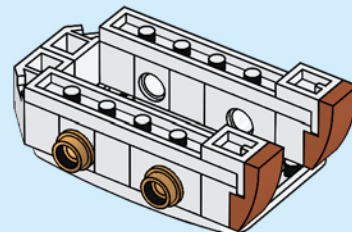

1x

63

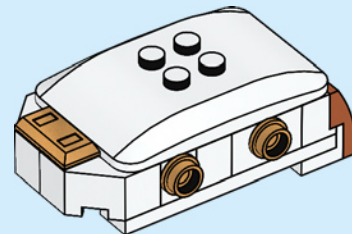

1x



1x

64

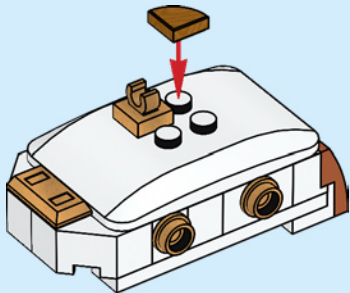

1x



1x

65

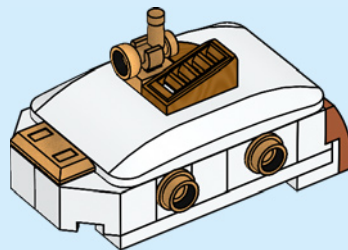

66

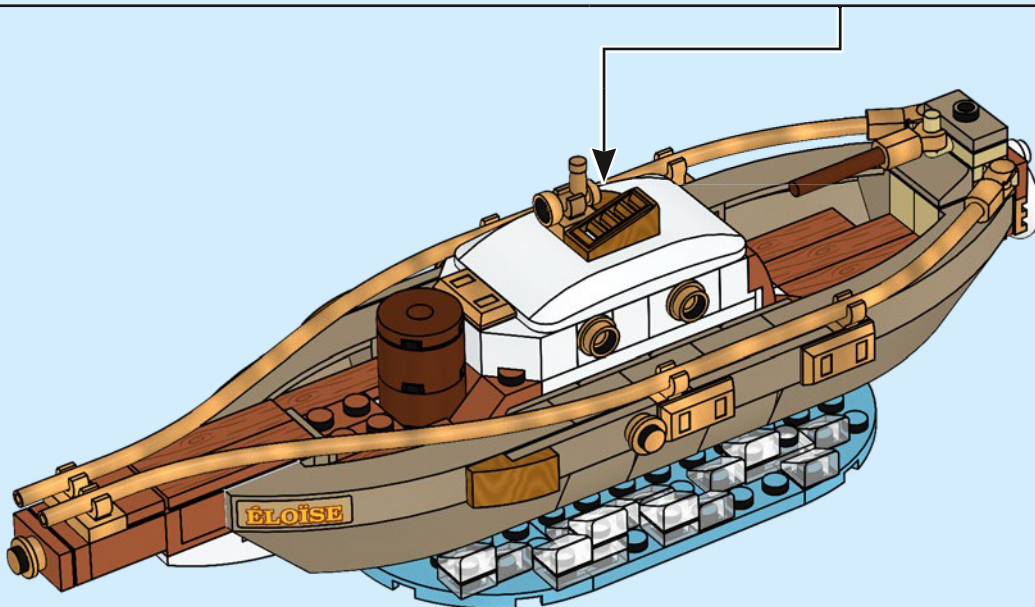

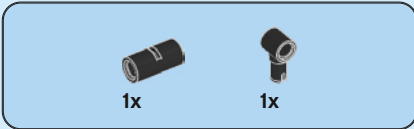
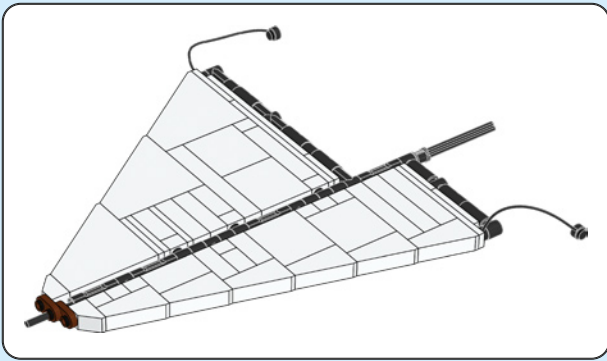

67

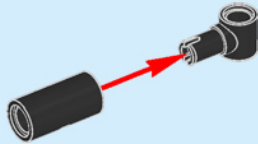

68

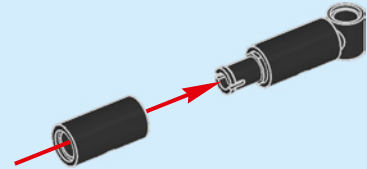

69

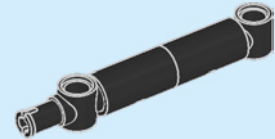



2x

70

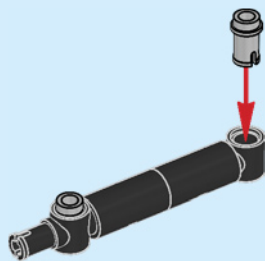

1x



1x

71

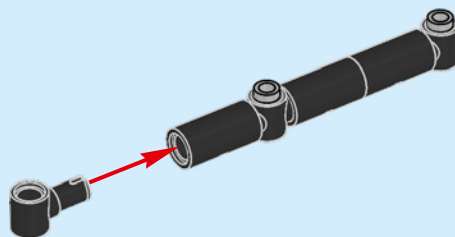



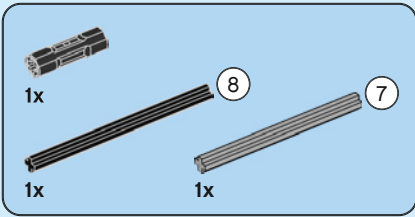

72

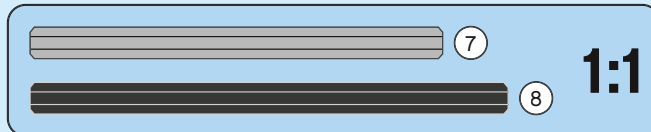
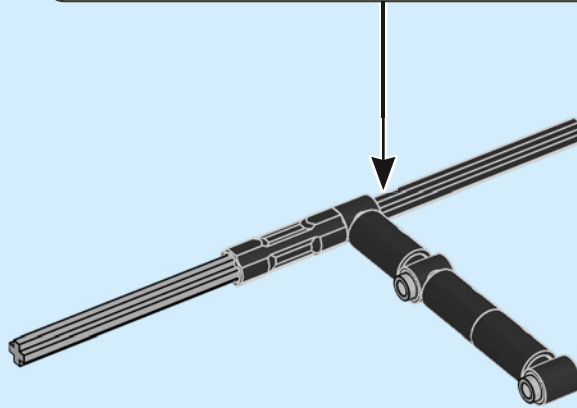
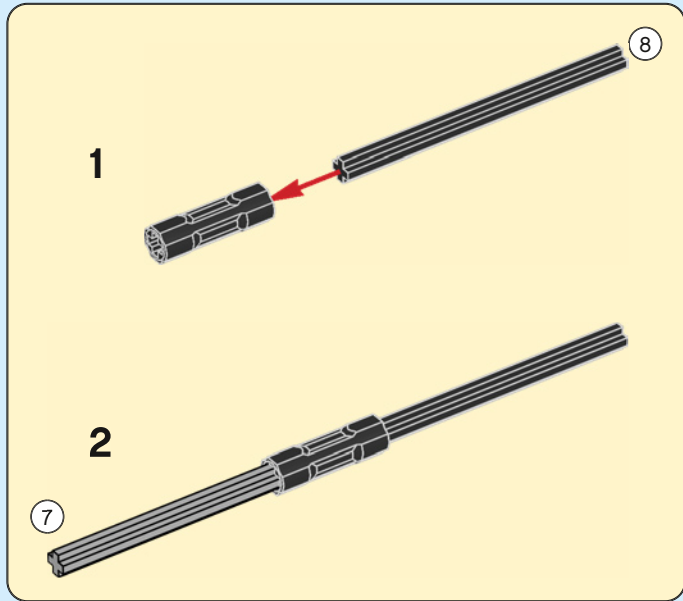



1x

73

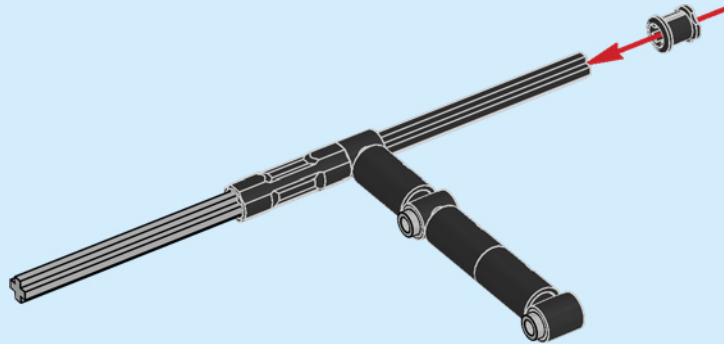

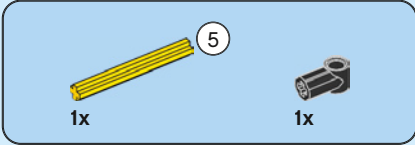

74

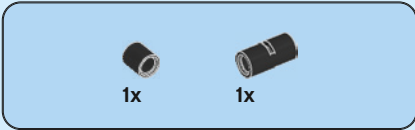
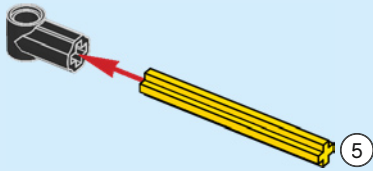

75

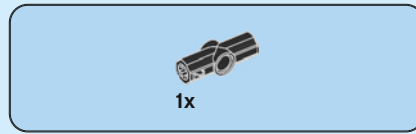
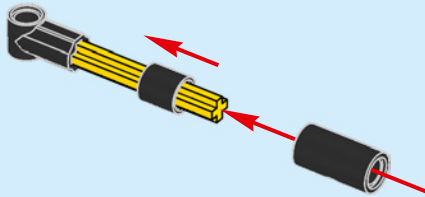

76

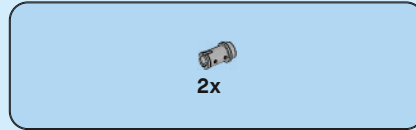
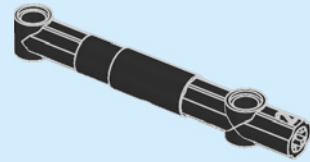

77

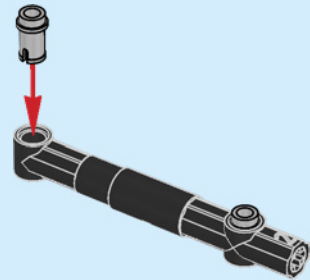

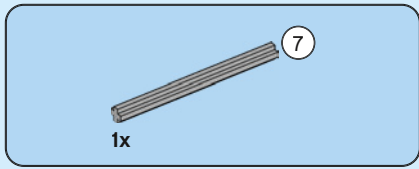

78

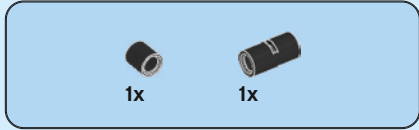
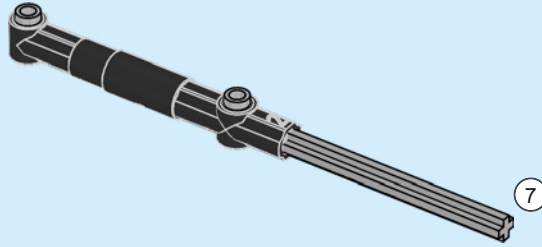
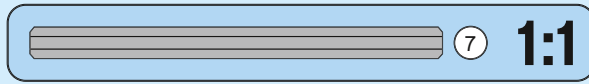

79

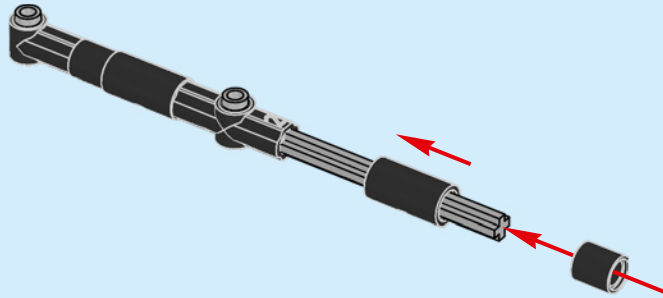

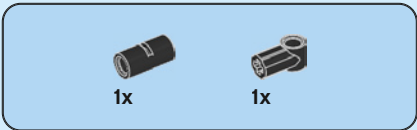

80

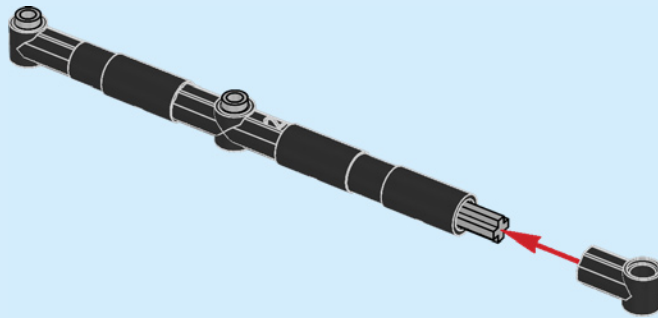

81

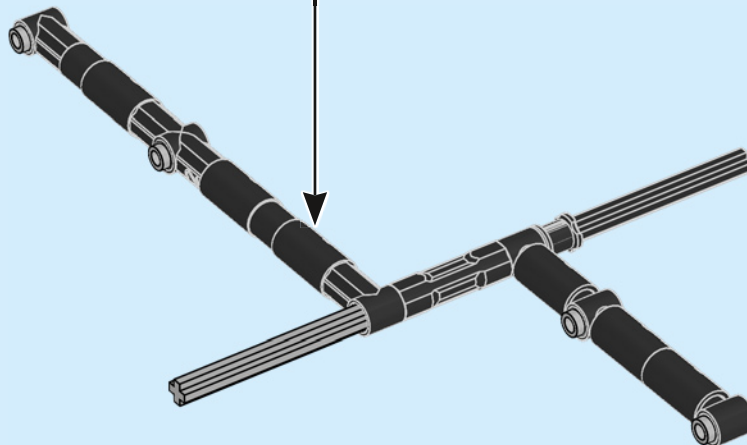



1x

82

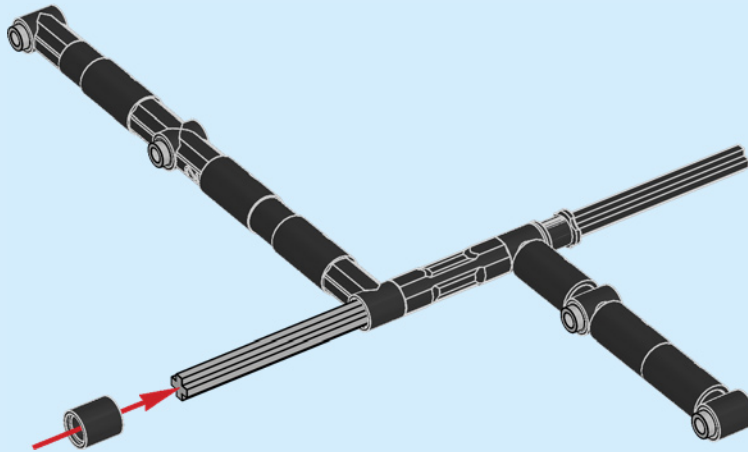

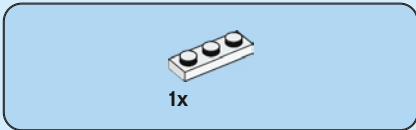
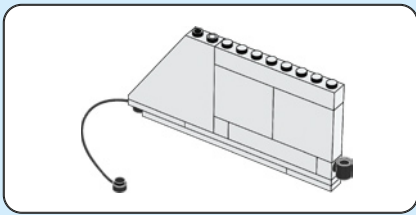

83

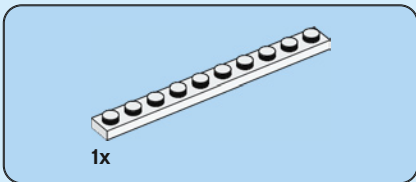
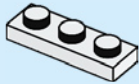

84

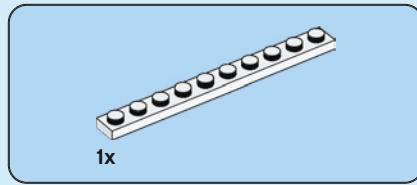
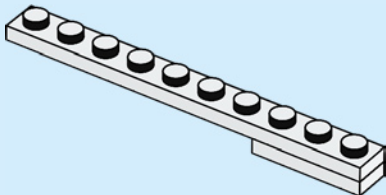

85

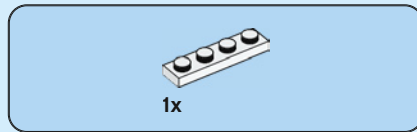
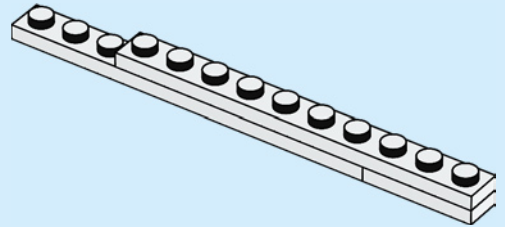

86

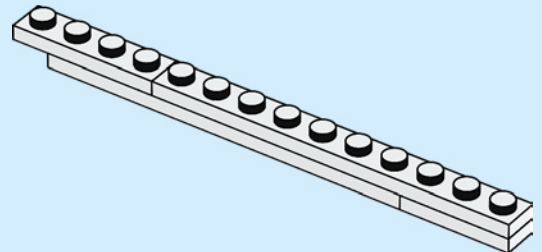

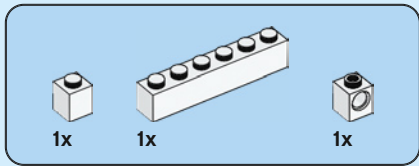

87

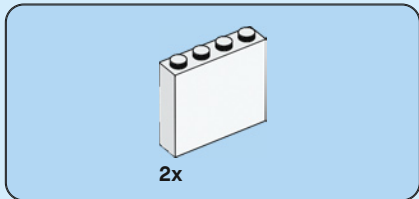
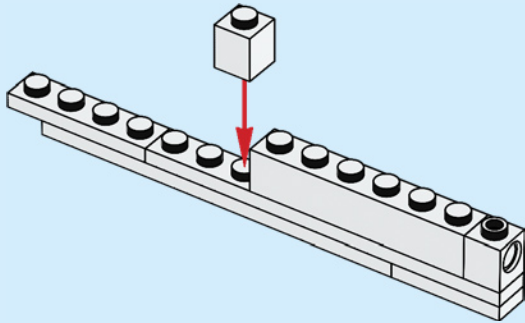

88

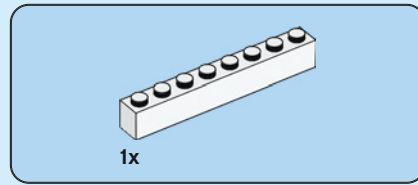
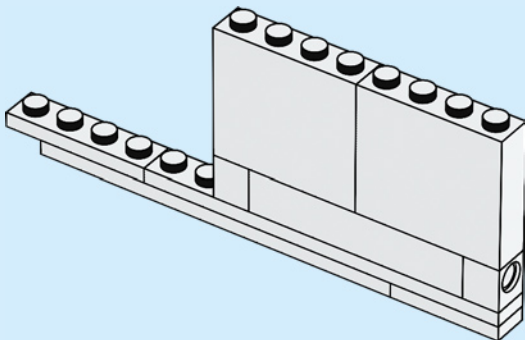

89

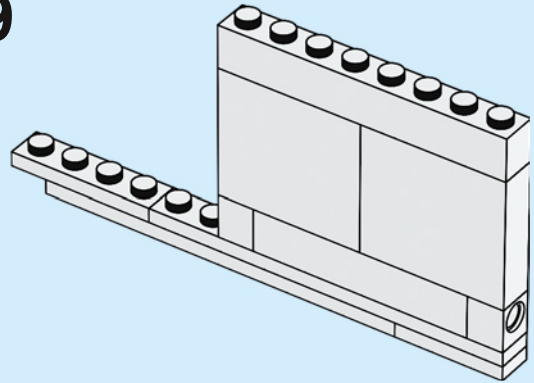

90

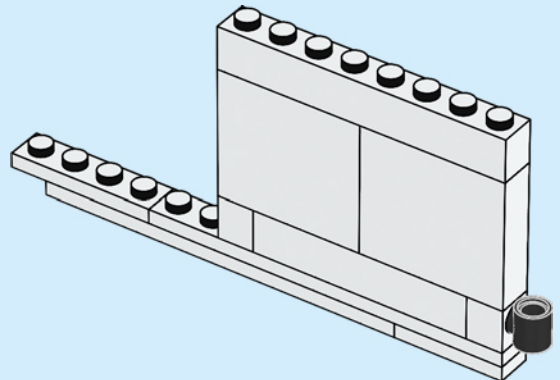



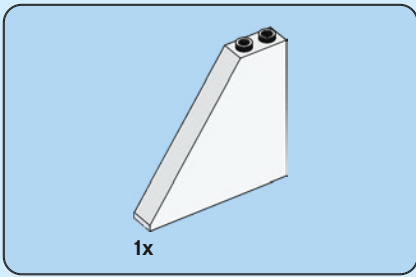

91

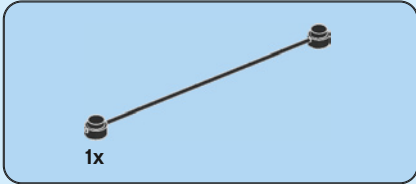
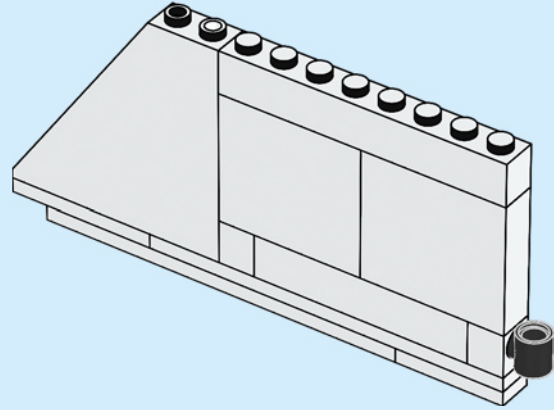

92

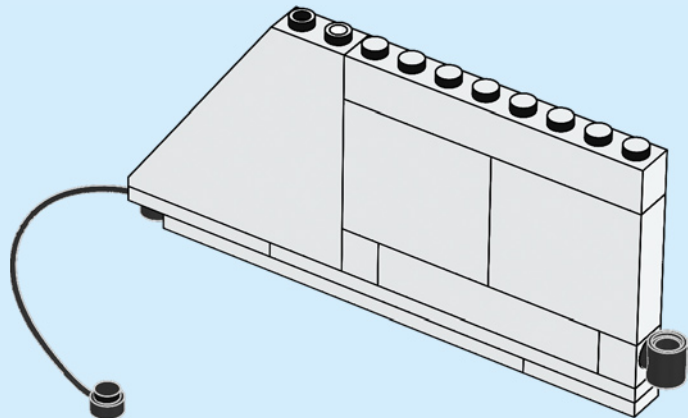

93

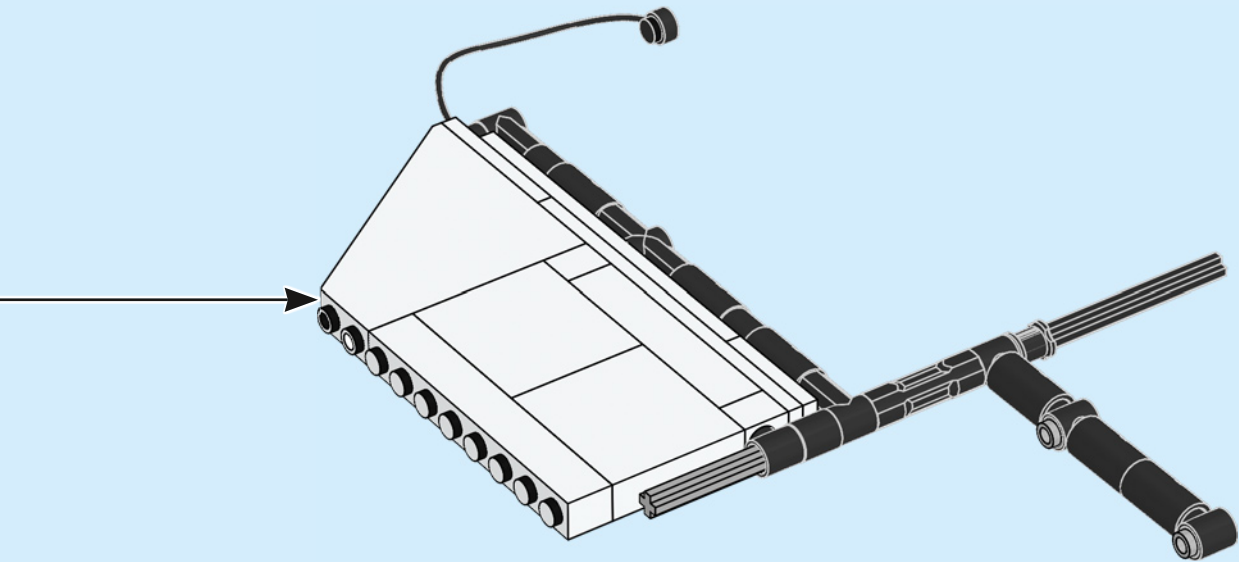



1x

94

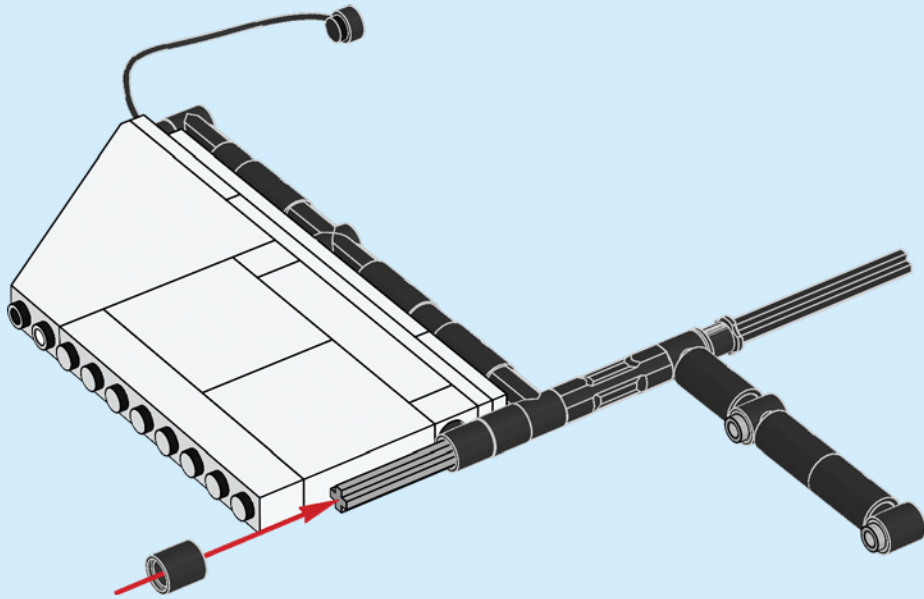

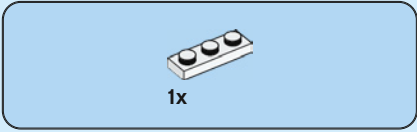
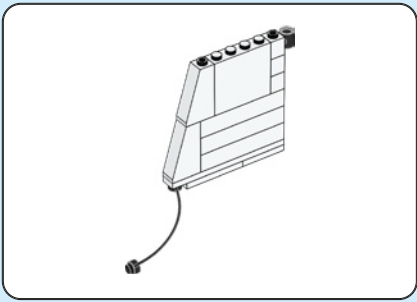

95

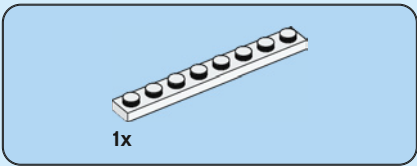
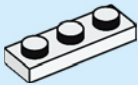

96

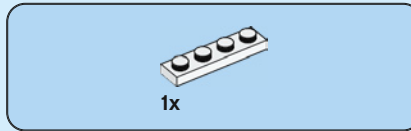
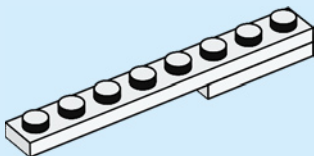

97

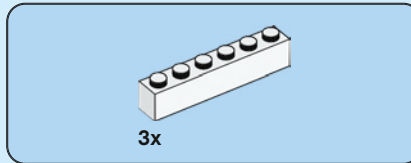
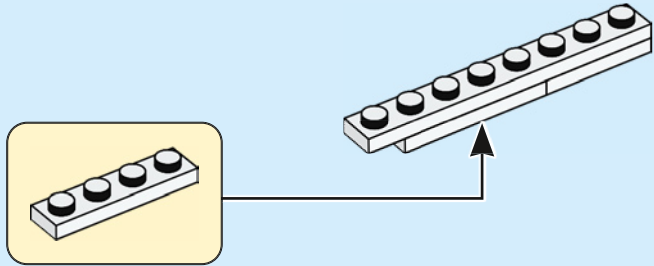

98

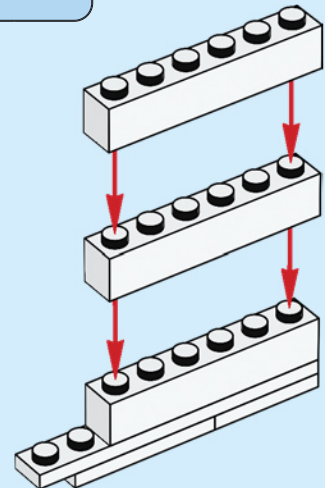

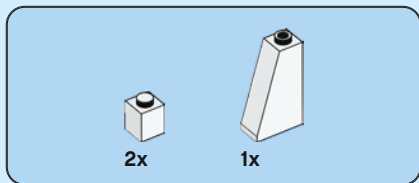

99

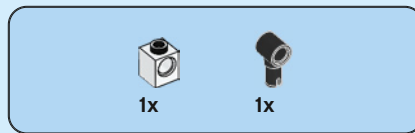
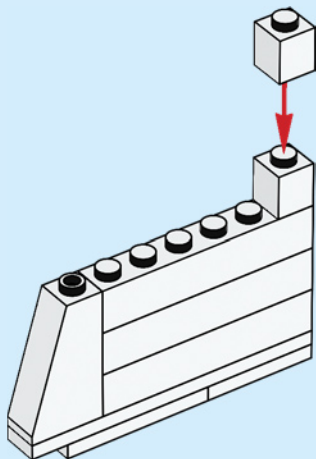

100

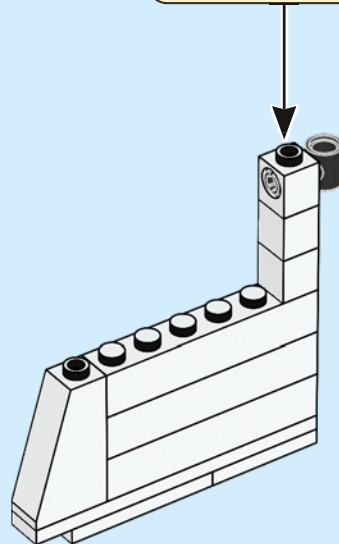
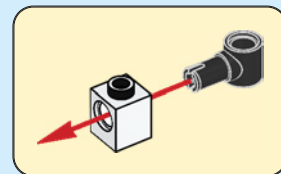

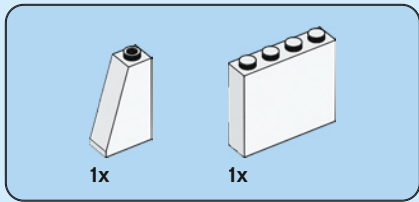

101

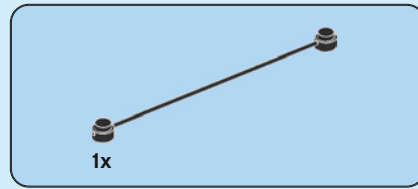
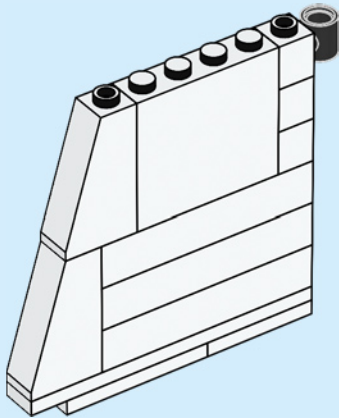

102

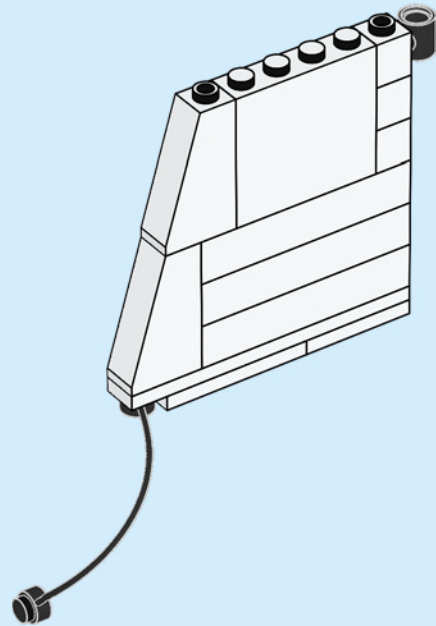

103

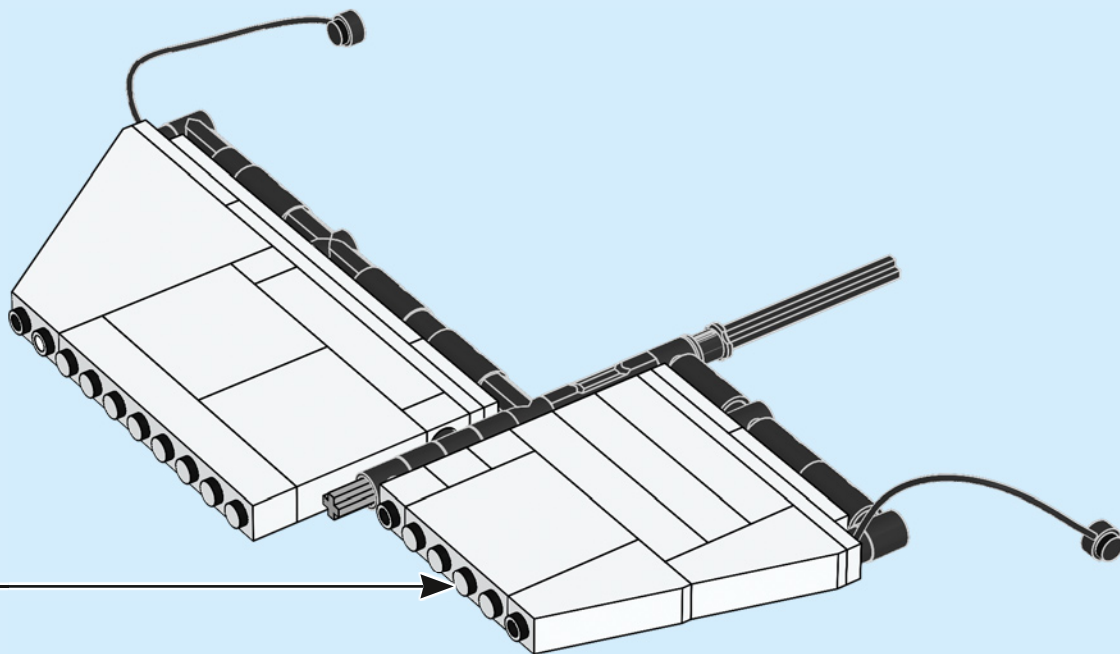

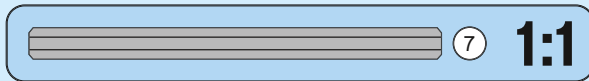
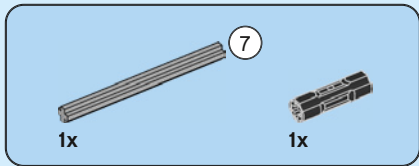

104

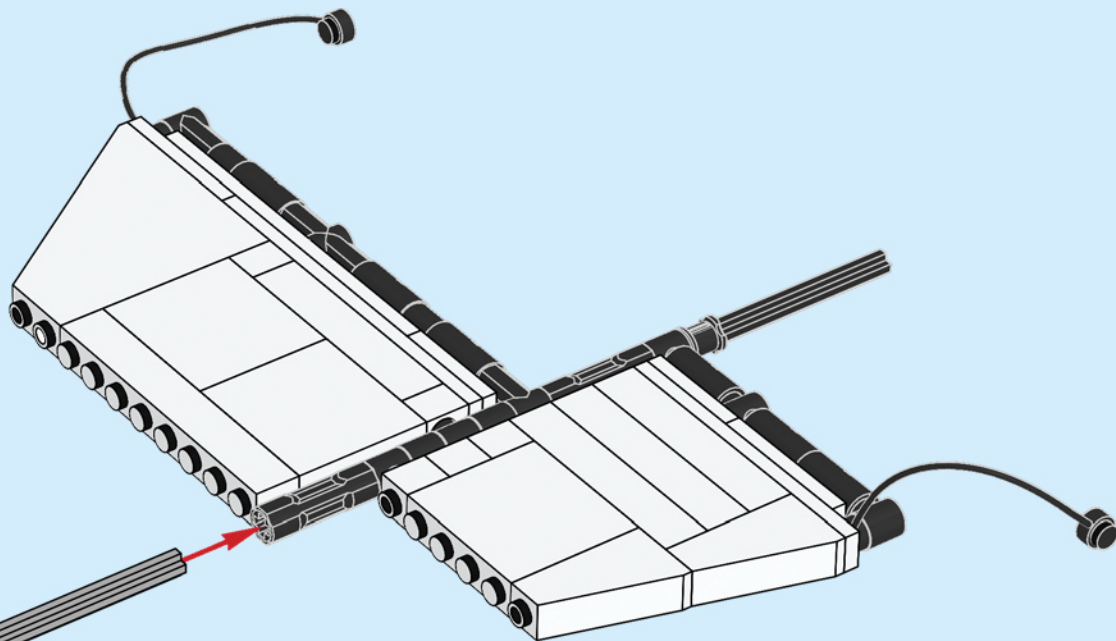



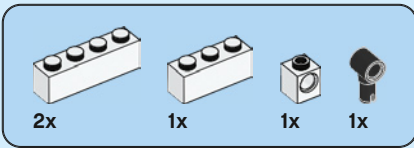

105

1

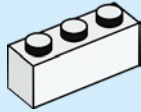

2

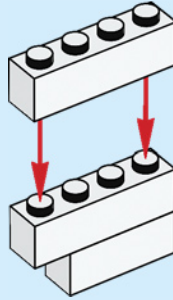

3

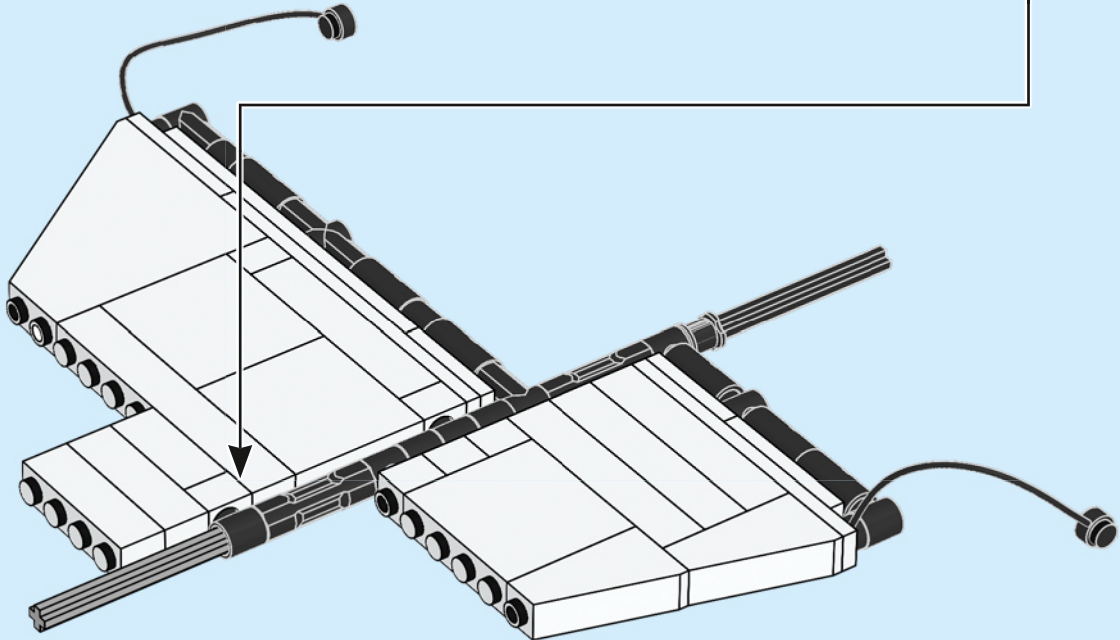
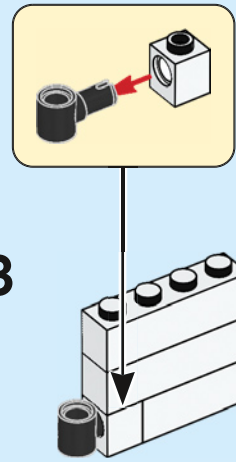

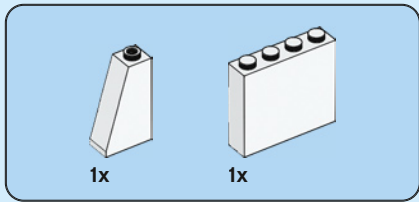

106

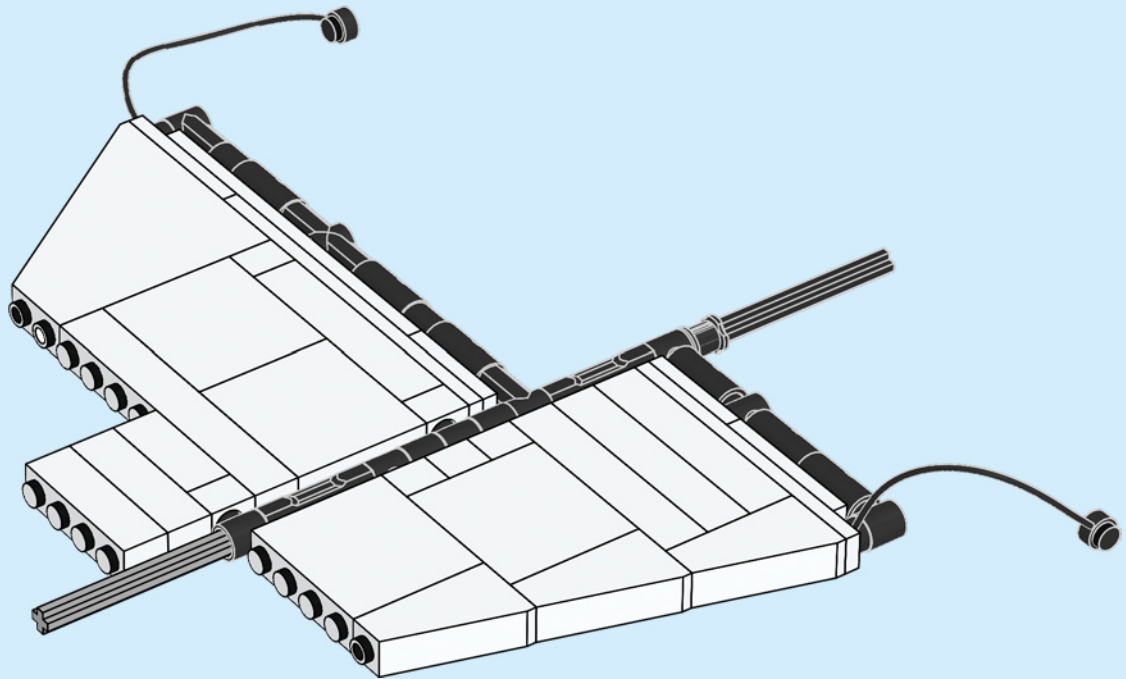



1x

107

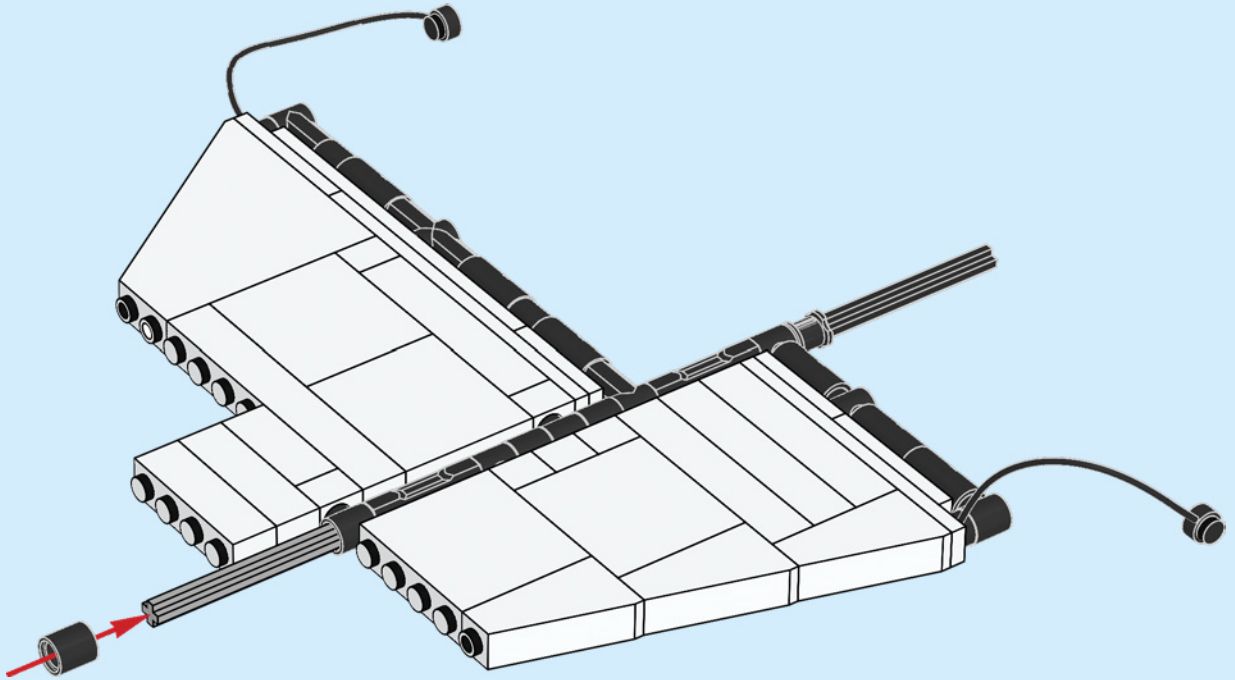

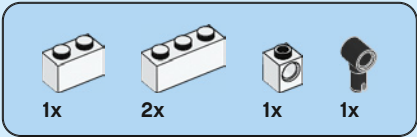

108

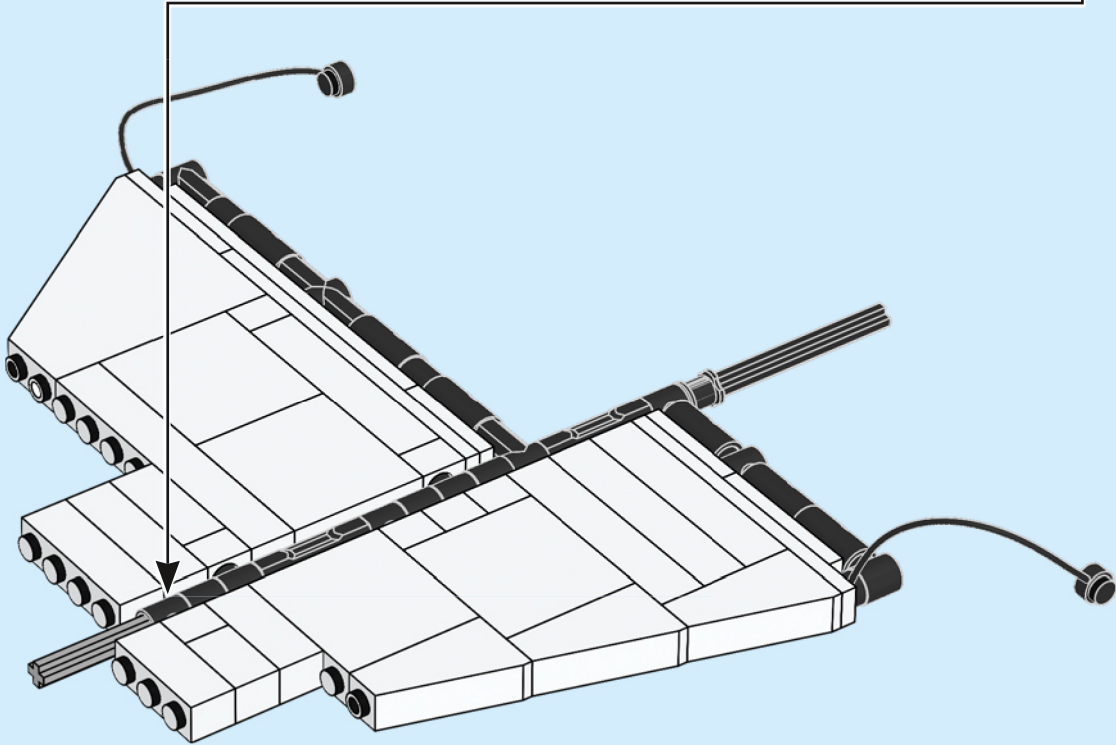
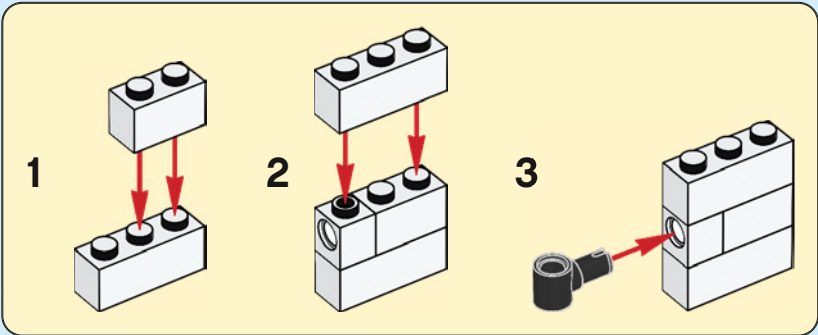



1x

# 109

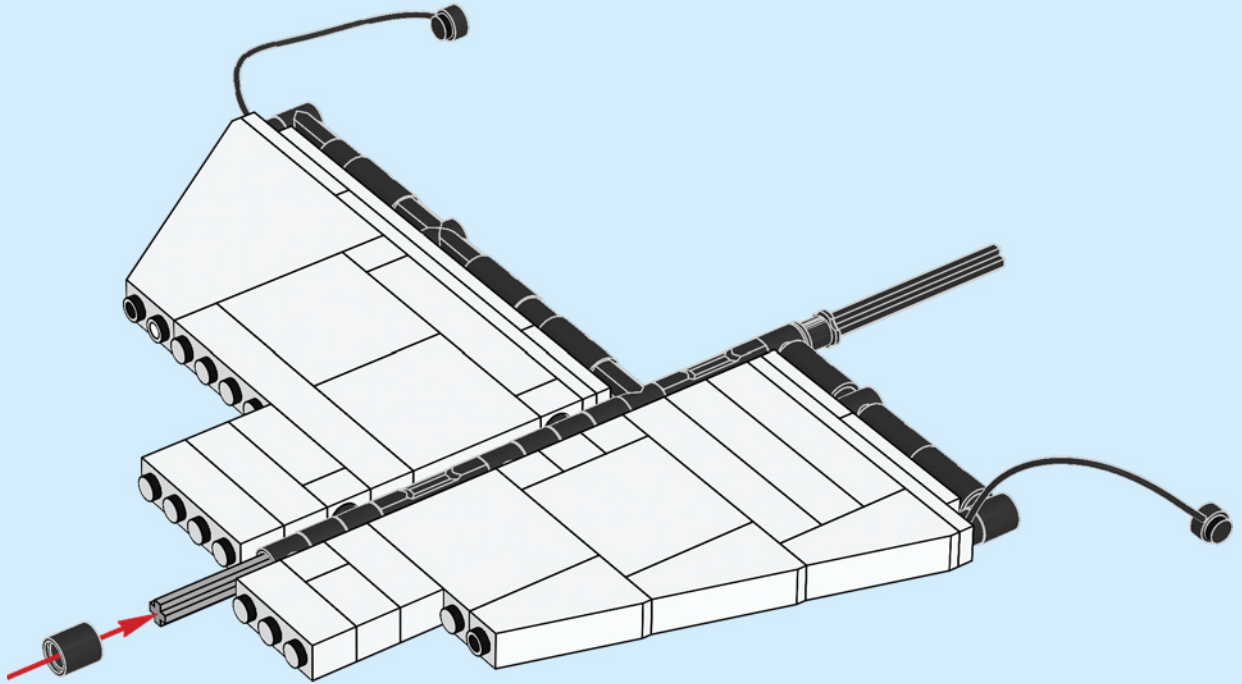

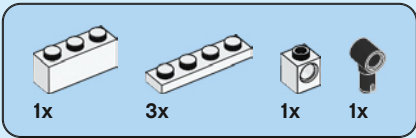

# 110

1

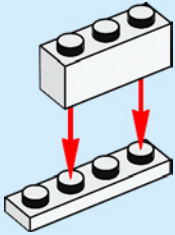

2

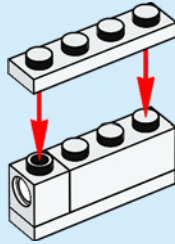

3

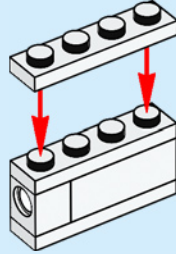

4

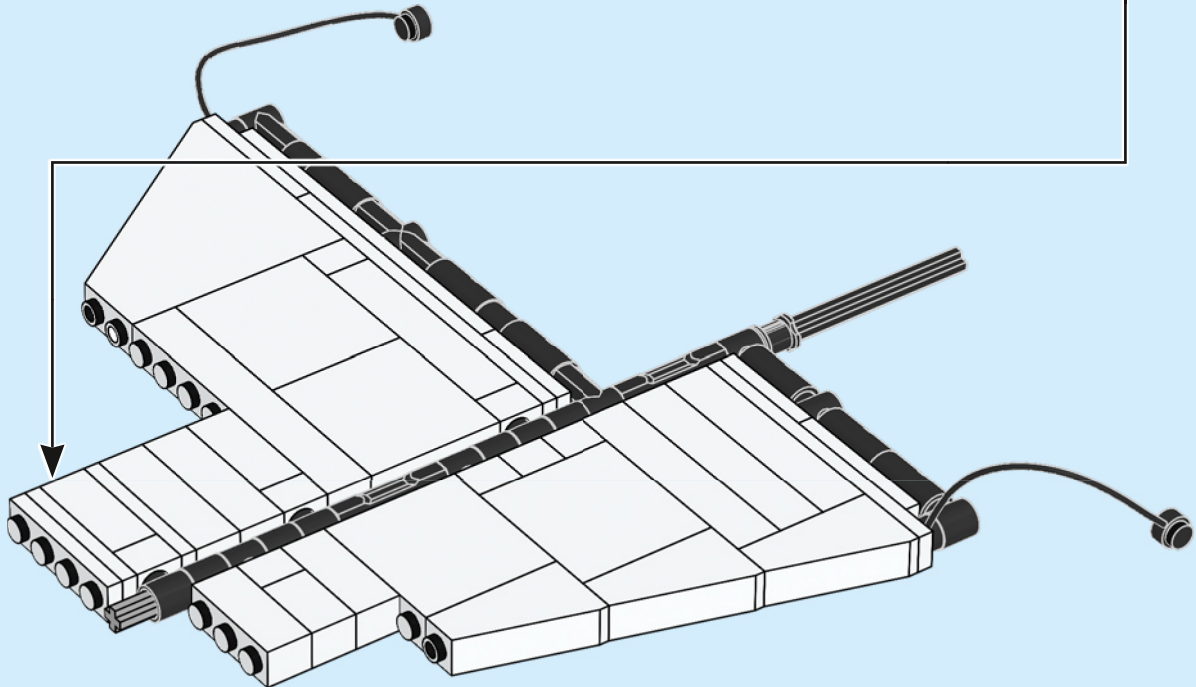
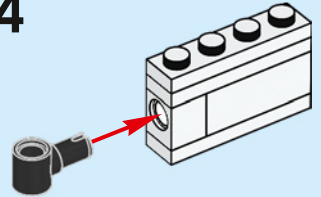

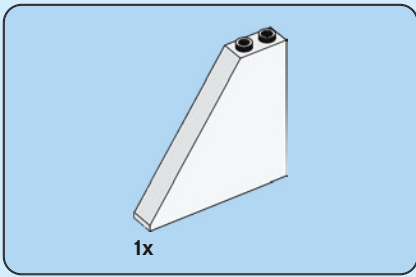

111

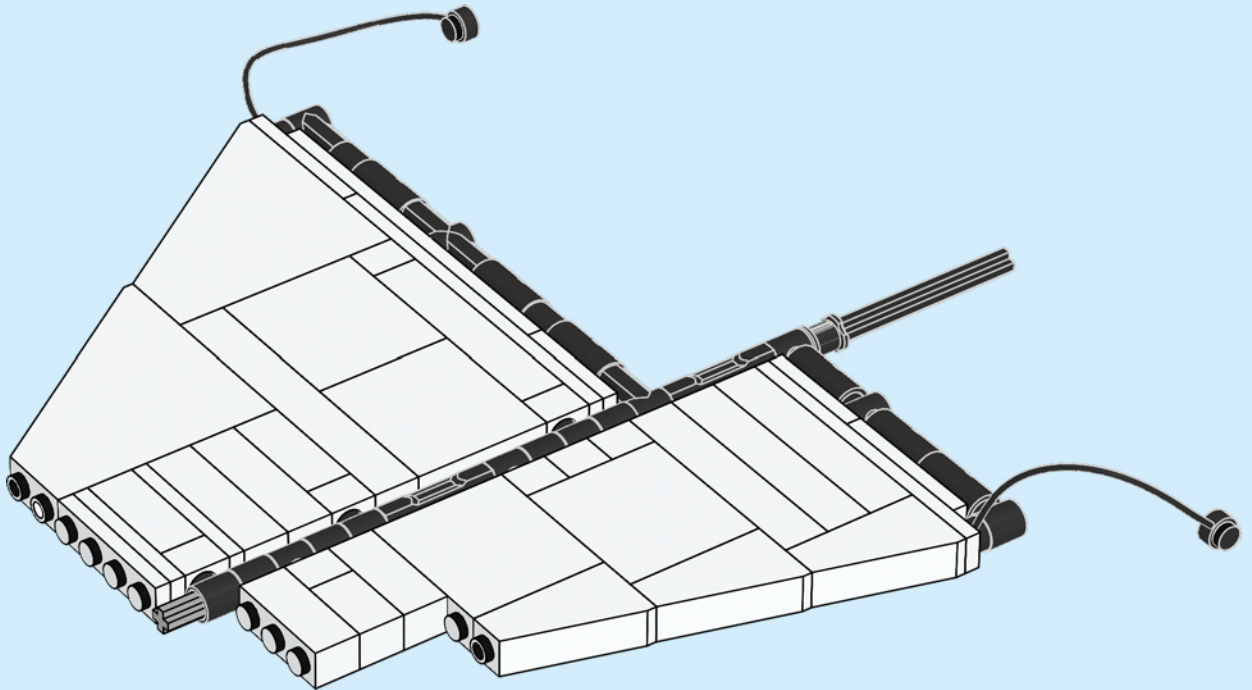

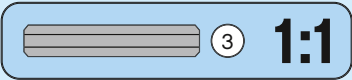
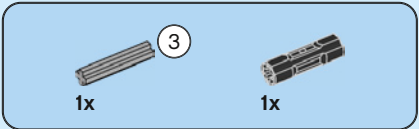

# 112

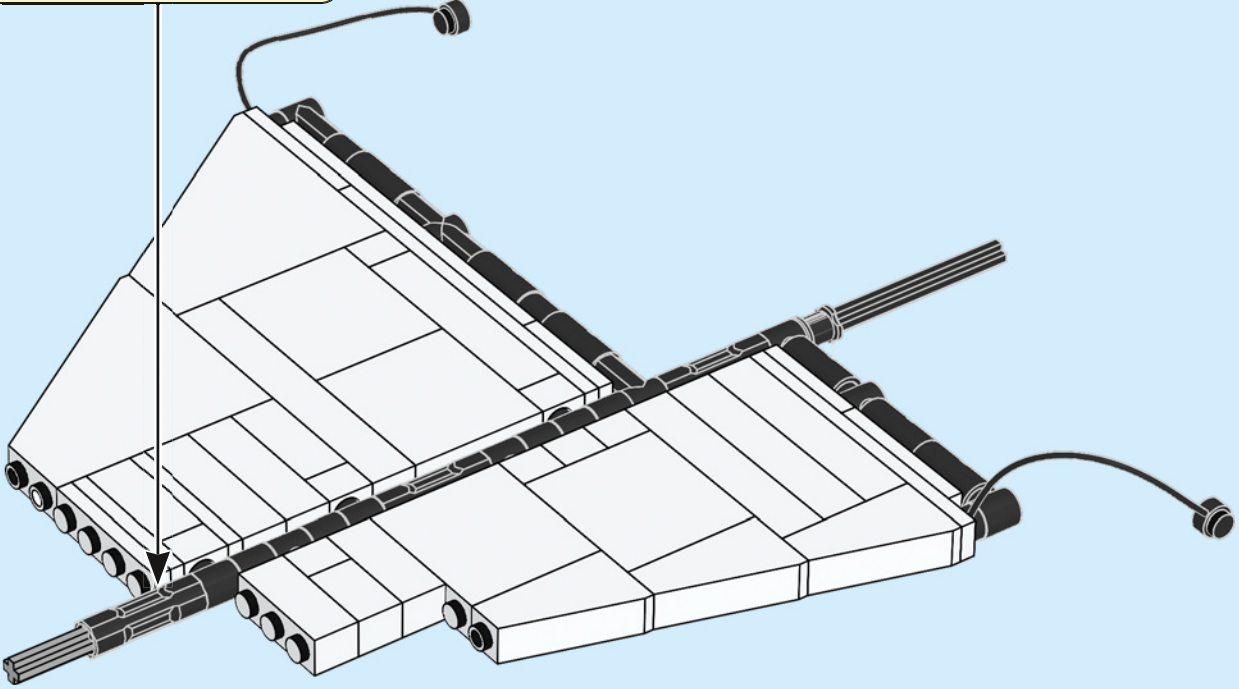
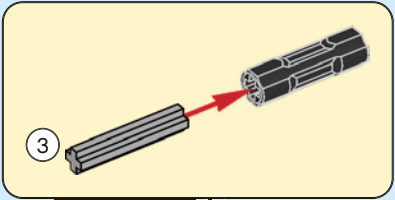



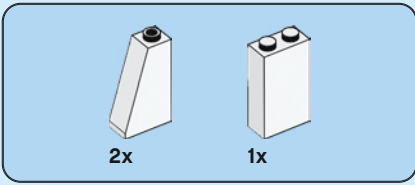

113

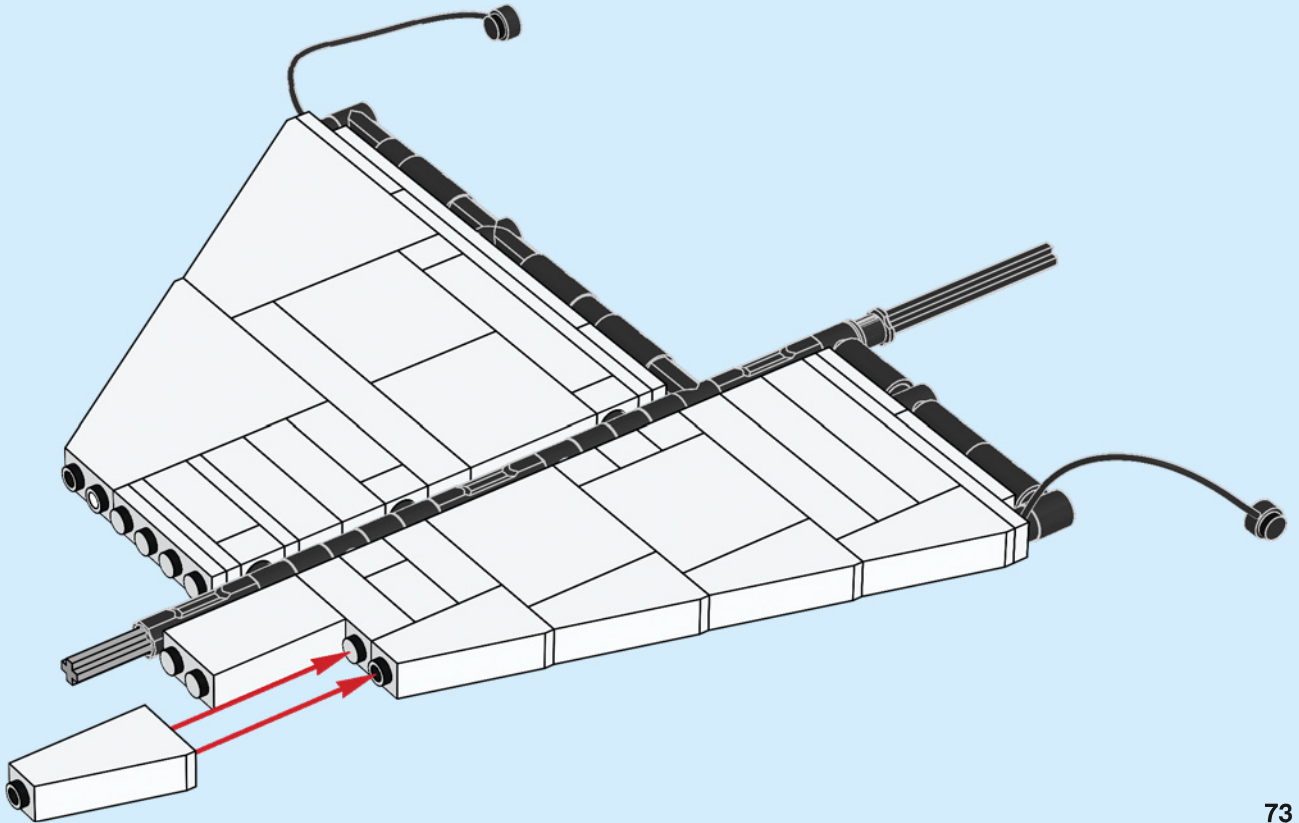

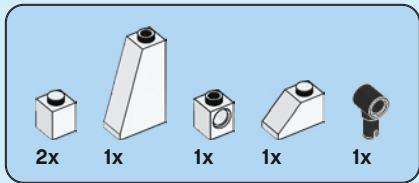

114

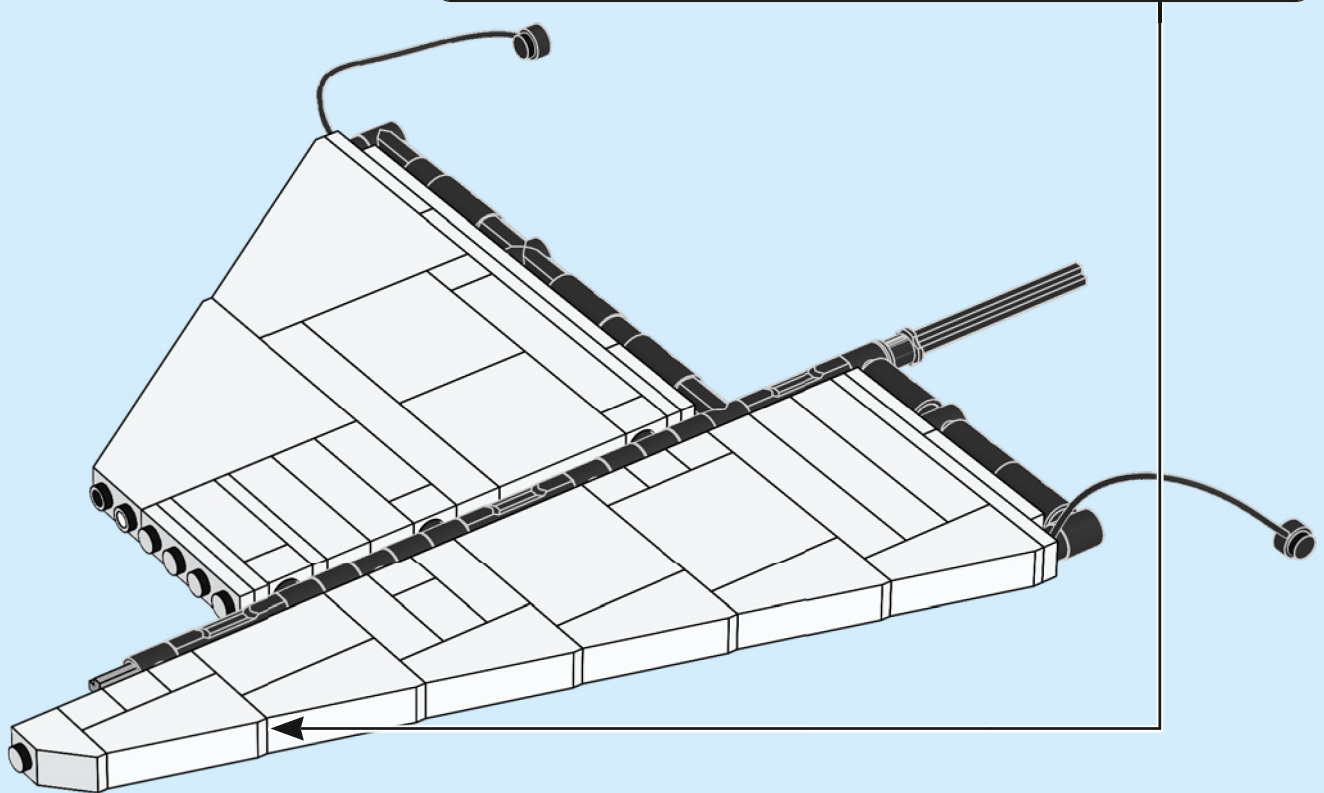
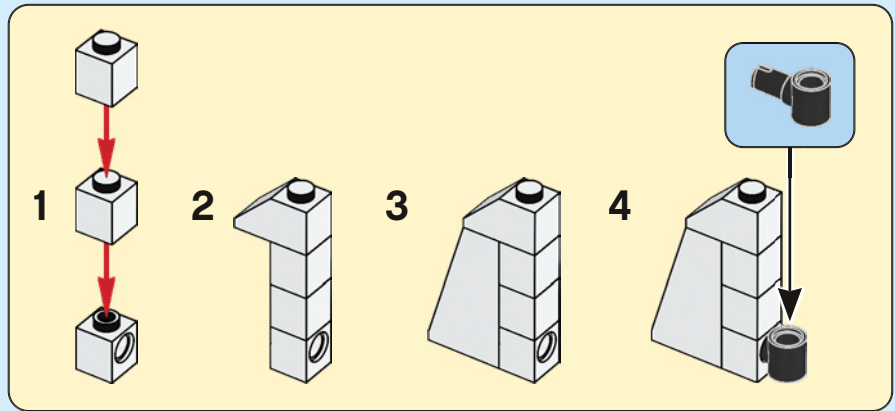

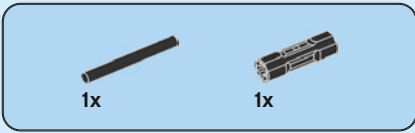

115

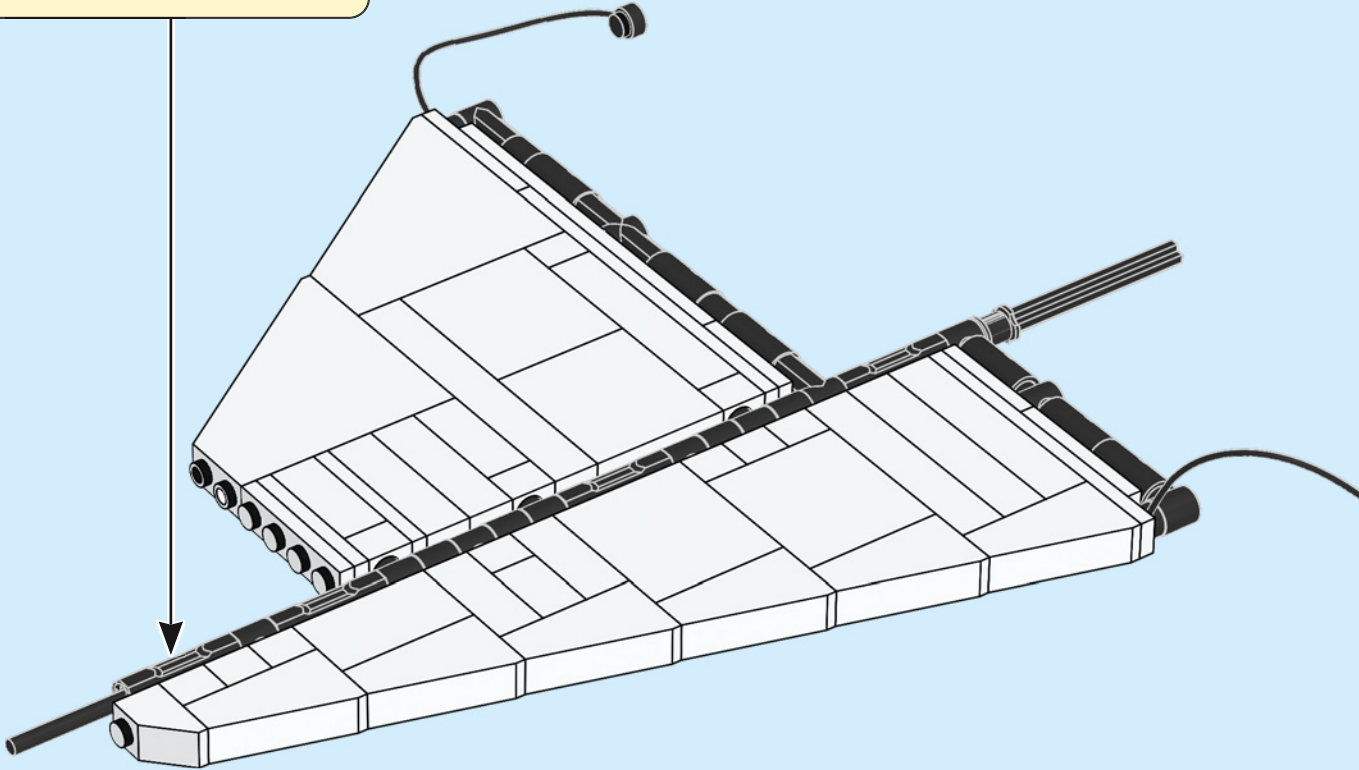
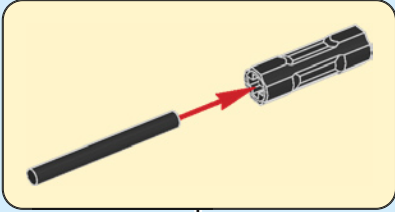

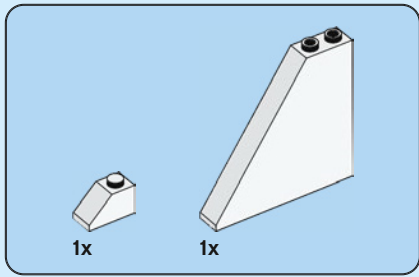

116

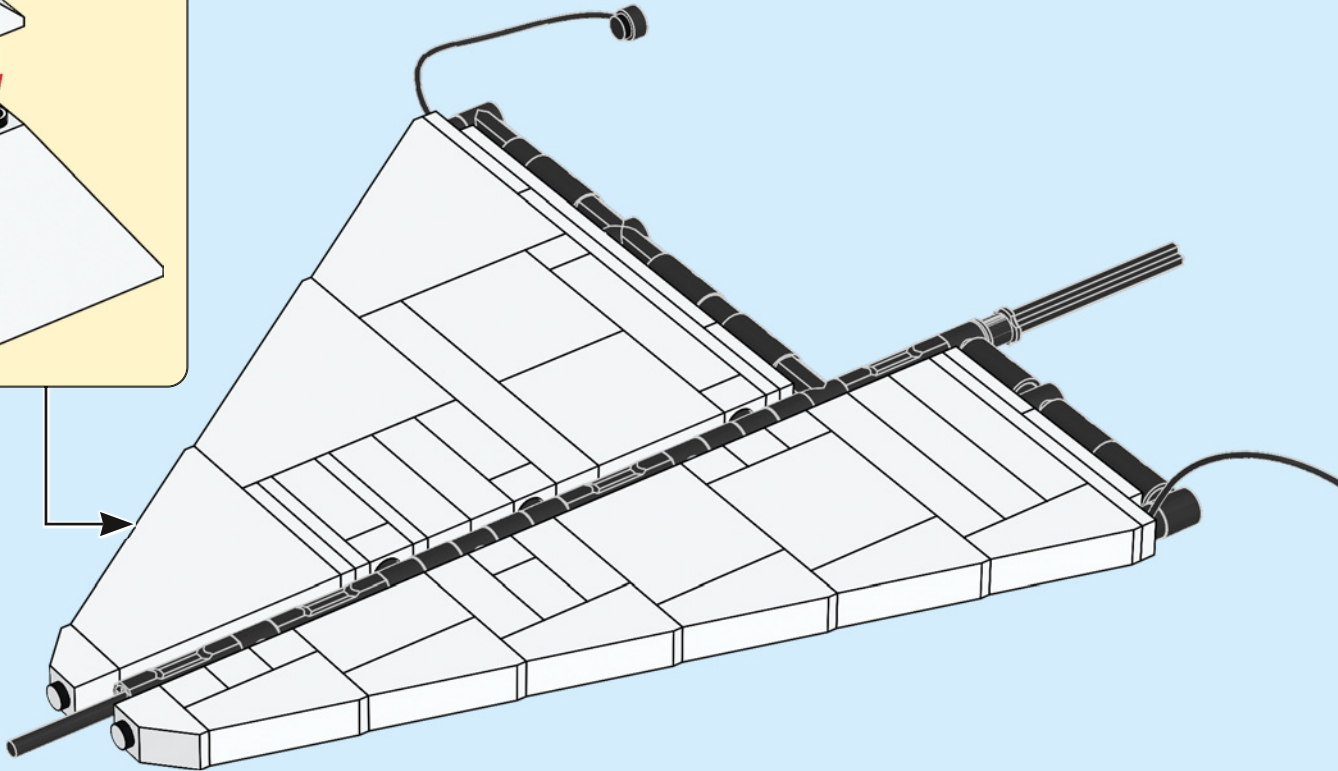
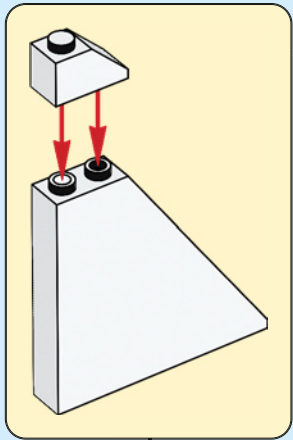



2x

117

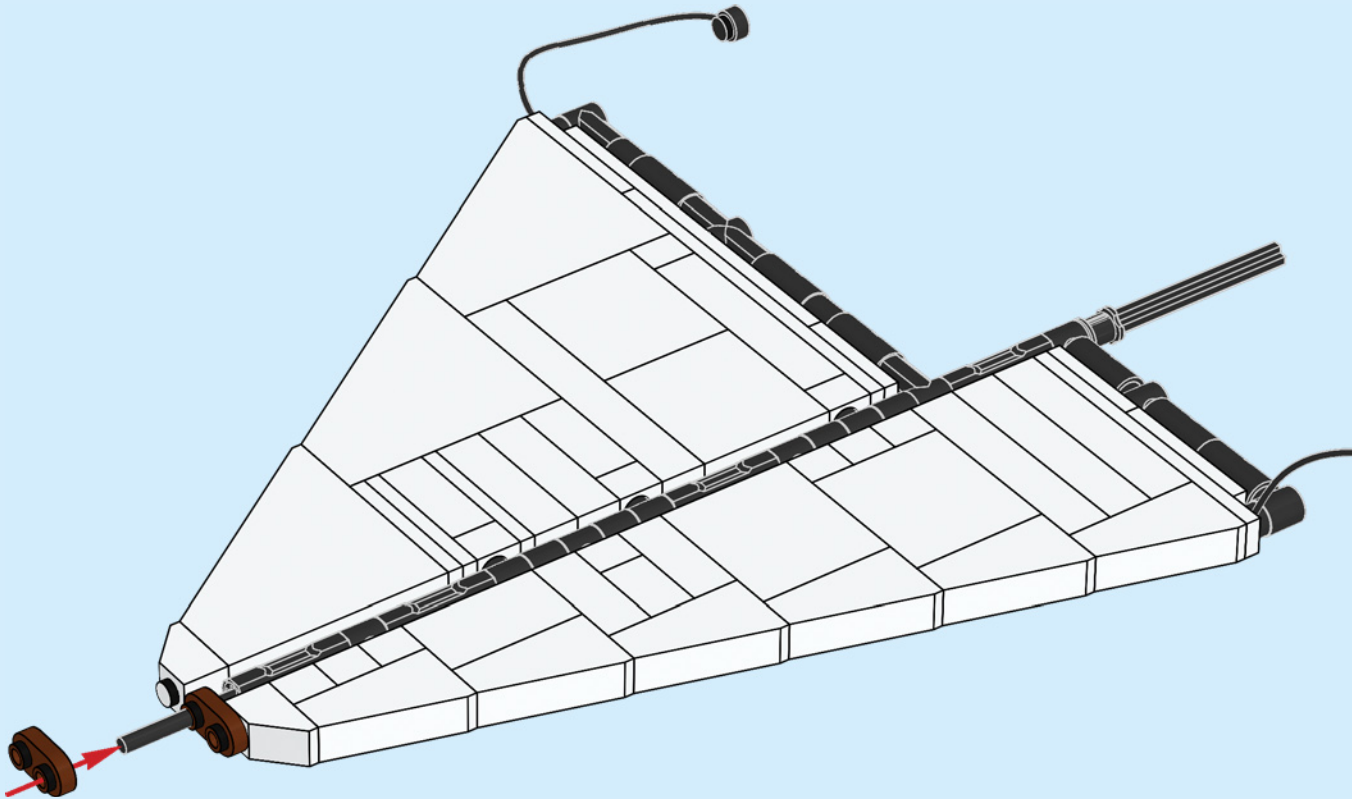

118

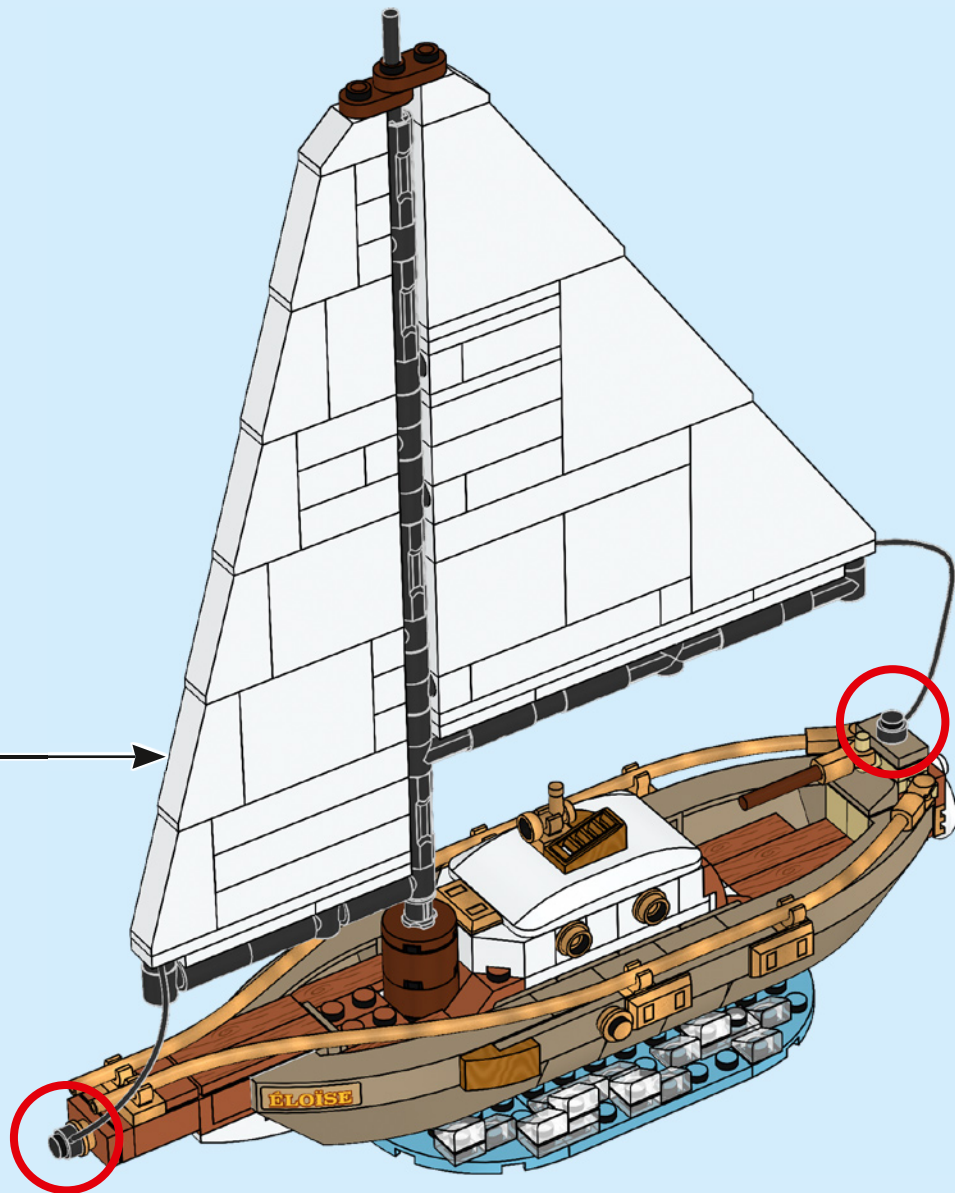

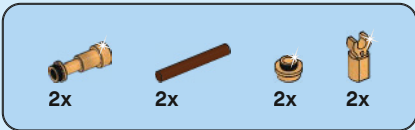

# 119

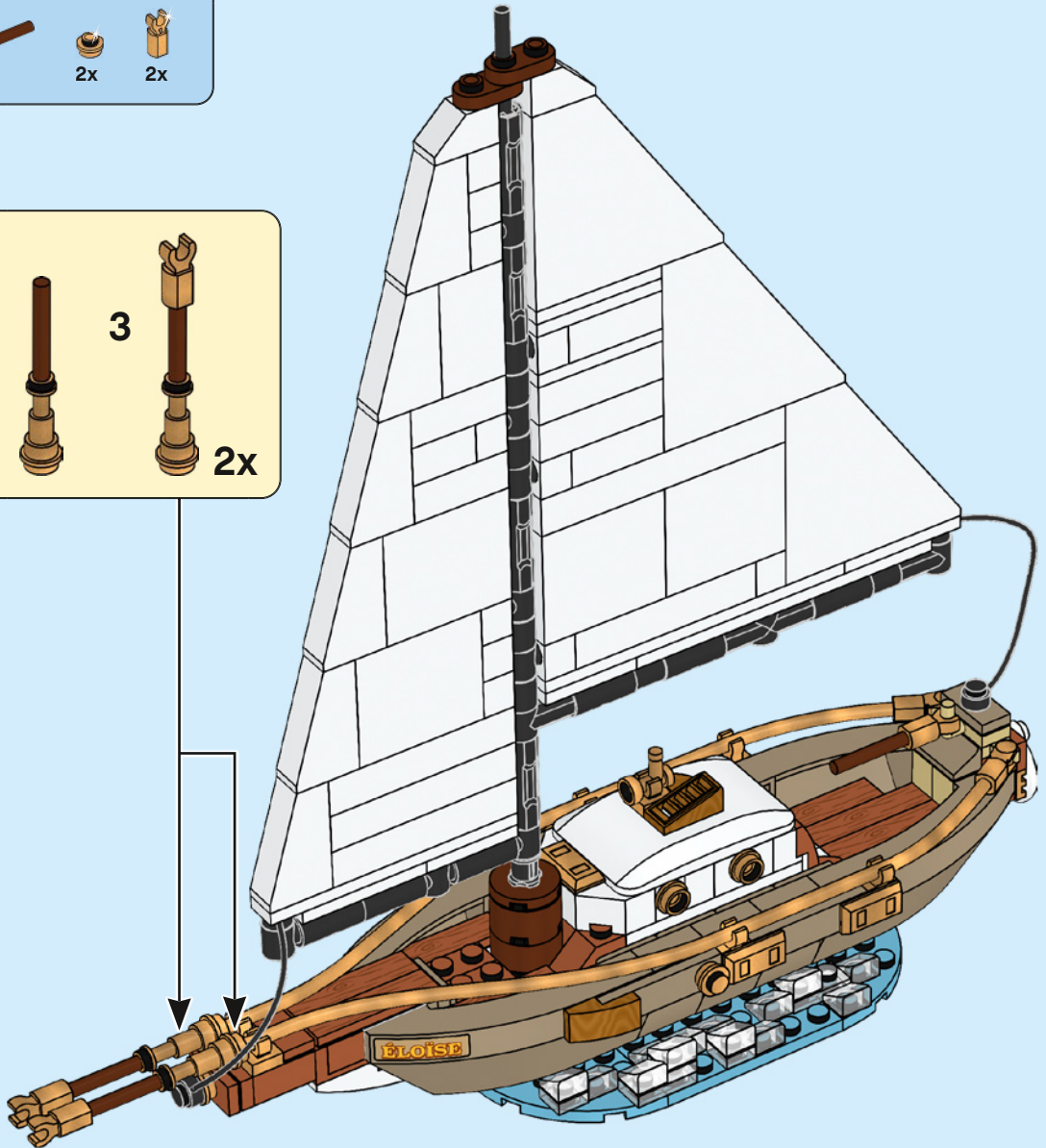
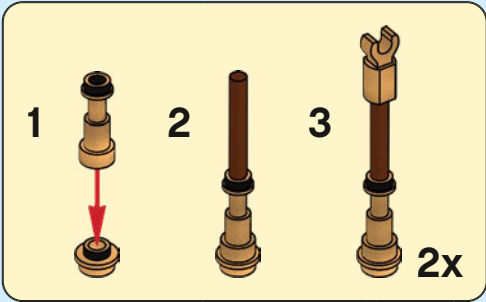



1x



1x

# 120

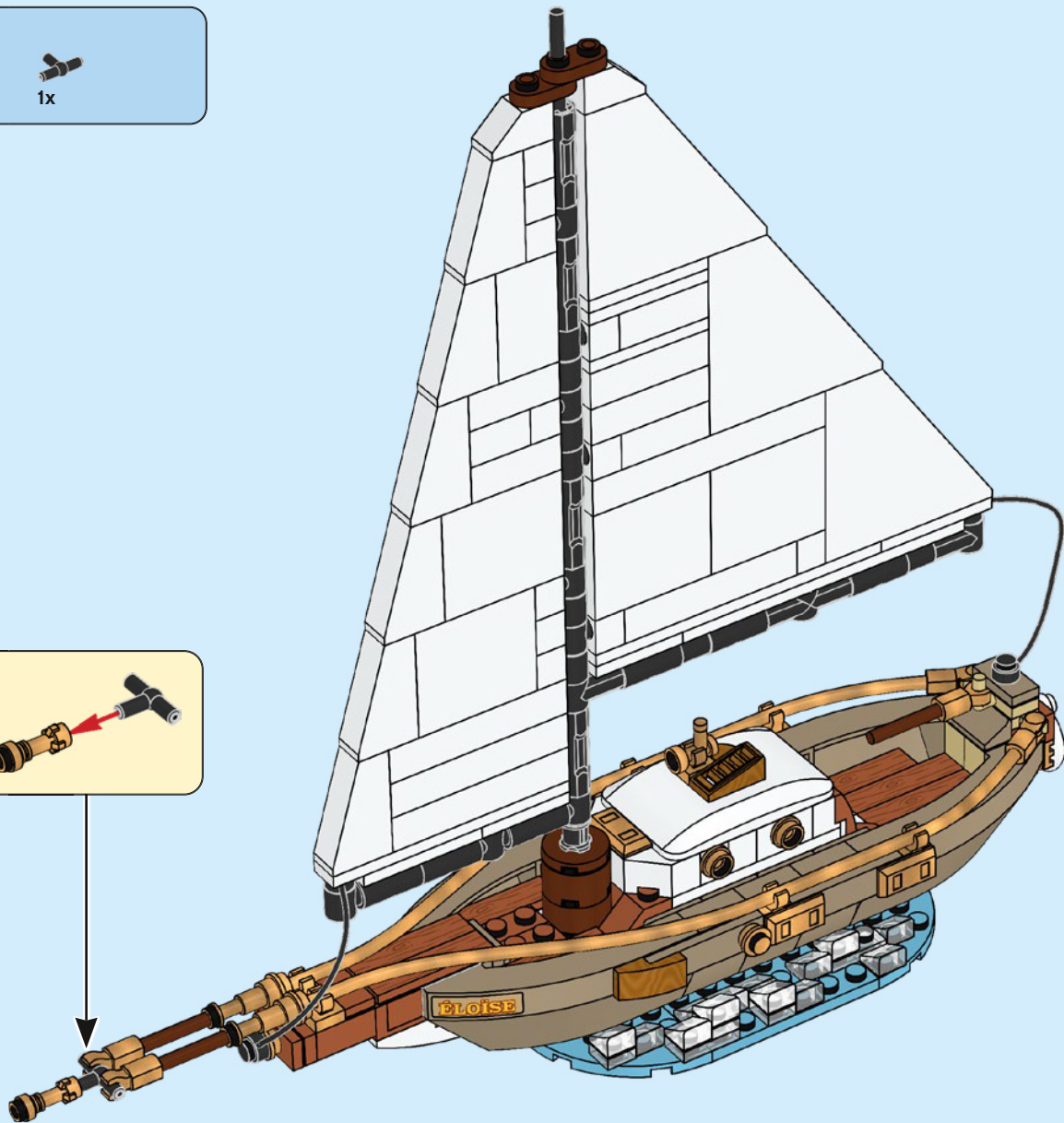
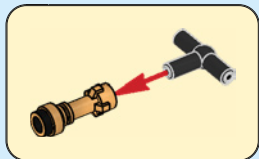



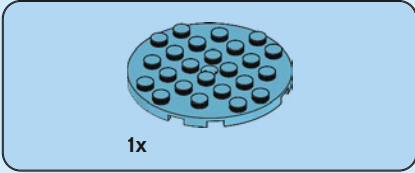
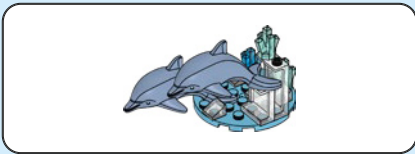

1

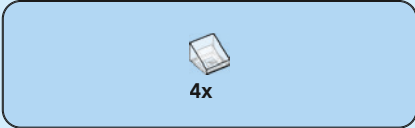
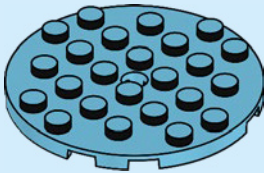

2

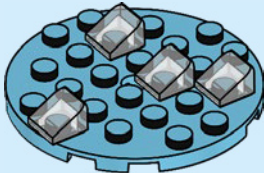

3

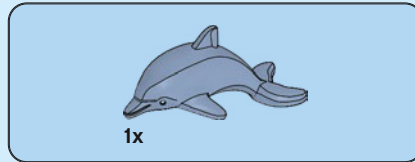
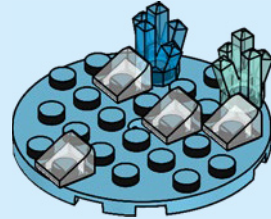

4

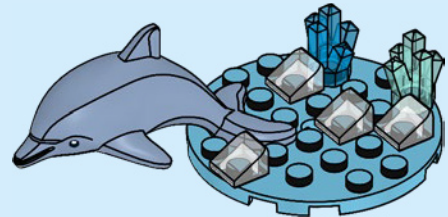



1x



1x

5

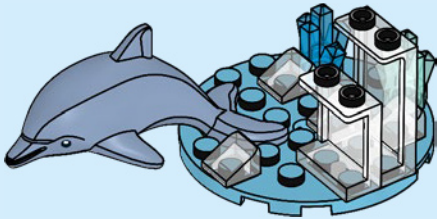

1x

6

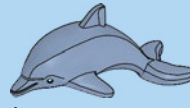
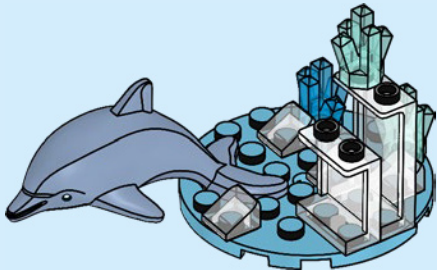

1x

7

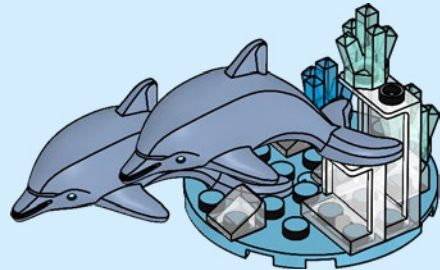

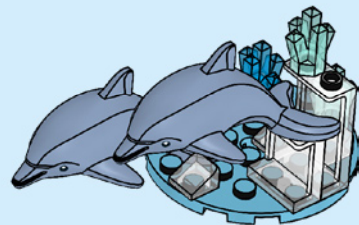
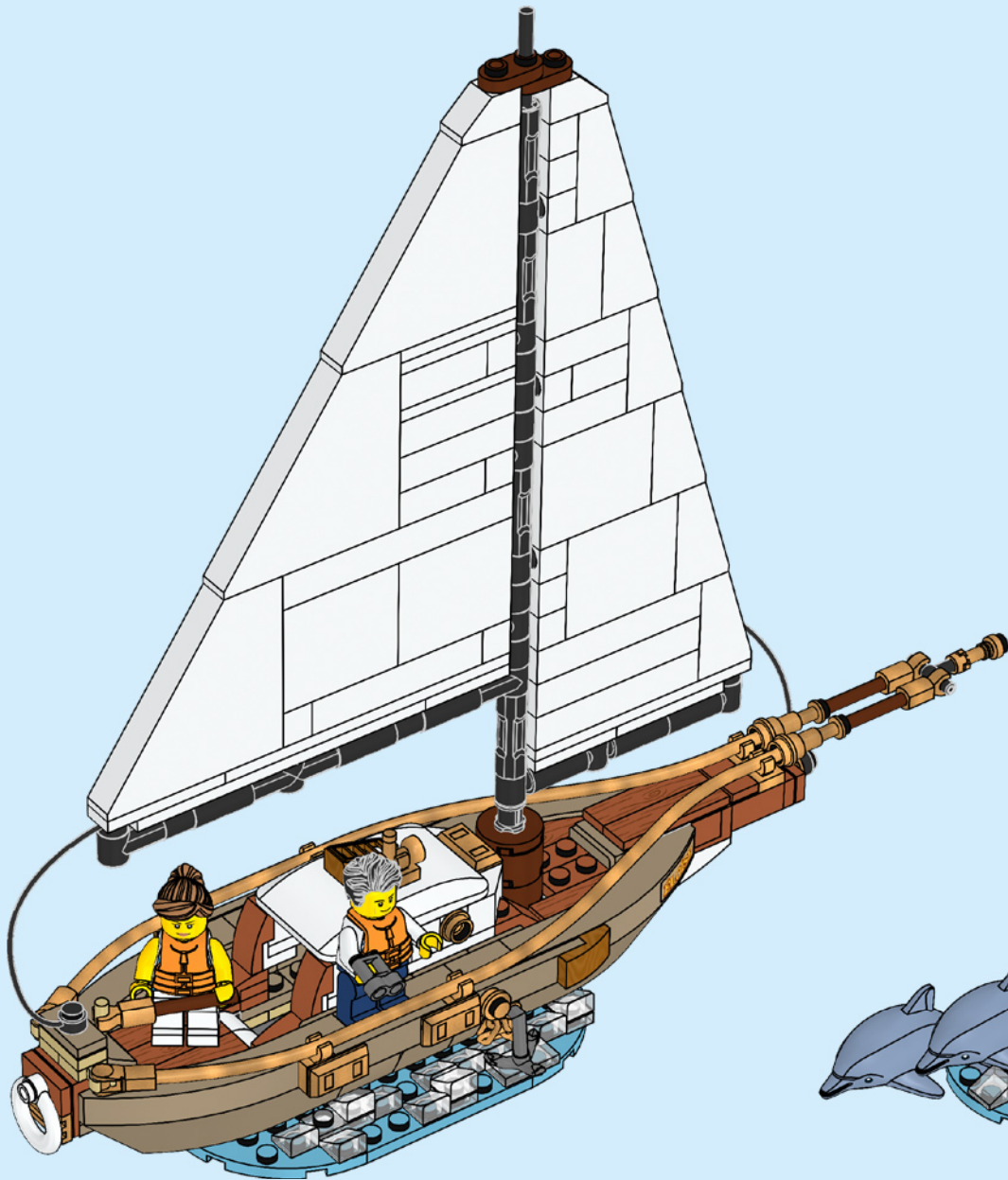



# IDEAS

GATHER SUPPORT  
OBTIENS DE L'APPUI  
OBTÉN APOYOS

SHARE YOUR IDEA  
PARTAGE TON IDÉE  
COMPARTE TU IDEA

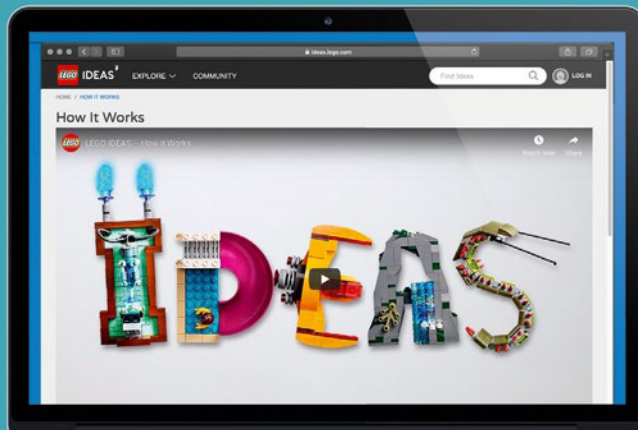

ideas.LEGO.com

NEW LEGO® PRODUCT  
NOUVEAU PRODUIT LEGO®  
NUEVO PRODUCTO LEGO®

LEGO® REVIEW  
EXAMEN LEGO®  
REVISIÓN DE LEGO®



Sesame Street® and associated characters, trademarks and design elements are owned and licensed by Sesame Workshop.  
© 2020 Sesame Workshop. All rights reserved.

©Disney. Based on the "Winnie the Pooh" works by A.A. Milne and E.H. Shepard.



5

8

1x  
6093260



1x  
6218359

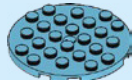

1x  
6029690



2x  
6138571

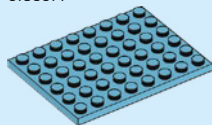

1x  
6097036



1x  
6251591



1x  
6294514



2x  
6294532



2x  
6296003



1x  
6236962



2x  
6327629



1x  
6015449

1x  
6101254



1x  
6092591



1x  
6310835



3x  
4521914



2x  
4528604



10x  
6330148



3x  
6093038



3x  
6047415



2x  
6363523



4x  
6257599



2x  
6361745



2x  
6361746



2x  
6361746



2x  
6361746

2x  
6361746

2x  
6248944



1x  
6092568



4x  
4211166



3x  
6075208



4x  
4211483



4x  
4211398



1x  
4211815



1x  
6347992



3x  
4211805



1x  
4211051



1x  
6269935



1x  
4227398



2x  
4257526



2x  
4257526

1x  
4162916



1x  
4296785



2x  
6231925



1x  
4490599



5x  
6207933



2x  
4538126



4x  
6284379



2x  
6322139



1x  
6003147



3x  
6252838



2x  
6296657



6x  
6190252



3x  
4523159



1x  
6146054



3x  
6262138



1x  
6323688



Customer Service  
Kundenservice  
Service Consommateurs  
Servicio Al Consumidor  
LEGO.com/service or dial

🇧🇪 🇩🇪 🇪🇺 🇫🇷 🇮🇹 🇯🇵 🇰🇷 🇸🇪 🇸🇯 🇺🇰 🇺🇸  
: 00800 5346 5555  
: 1-800-422-5346

# WIN

GO TO [WWW.LEGO.COM/PRODUCTFEEDBACK](http://WWW.LEGO.COM/PRODUCTFEEDBACK) AND  
GIVE US YOUR SHORT **FEEDBACK** ABOUT THIS  
LEGO® SET FOR A CHANCE TO WIN  
A COOL LEGO PRIZE.

Terms & Conditions apply

## [LEGO.com/productfeedback](http://LEGO.com/productfeedback)



### GEWINNE

Erzähle uns auf  
[www.LEGO.com/productfeedback](http://www.LEGO.com/productfeedback)

etwas über die Erfahrungen, die du mit  
diesem LEGO® Set gemacht hast, und  
sichere dir die Chance auf einen coolen  
LEGO Preis!

Es gelten die Teilnahmebedingungen

### GAGNE

Rends-toi sur  
[www.LEGO.com/productfeedback](http://www.LEGO.com/productfeedback)

et donne-nous quelques commentaires  
sur ce produit LEGO® pour avoir une  
chance de gagner un prix LEGO !

Voir Conditions Générales

### GANANA

Visita  
[www.LEGO.com/productfeedback](http://www.LEGO.com/productfeedback)

y envíanos tu opinión acerca de este set  
LEGO®. ¡Participarás en el sorteo de un  
premio LEGO!

Términos y Condiciones aplicables

### 获取奖品

登录  
[www.LEGO.com/productfeedback](http://www.LEGO.com/productfeedback)

给出关于此乐高®套装的简短反馈，  
就有机会获得炫酷乐高奖品

《条款及条件》适用